

# Secondary Physics 1

Secondary Physics has been written and developed by Ministry of General Education and Instruction, Government of South Sudan in conjunction with Subjects experts. This course book provides a fun and practical approach to the subject of Physics, and at the same time imparting life long skills to the students.

The book comprehensively covers the Secondary 1 syllabus as developed by **Ministry of General Education and Instruction.**

Each year comprises of a **Student's Book** and **teacher's Guide.**

The **Teacher's Guides** provide:

- Full coverage of the national syllabus.
- A strong grounding in the basics of Physics.
- Clear presentation and explanation of learning points.
- A wide variety of practice exercises, often showing how Physics can be applied to real-life situations.
- It provides opportunities for collaboration through group work activities.
- Stimulating illustrations.



All the courses in this secondary series were developed by the **Ministry of General Education and Instruction, Republic of South Sudan.** The books have been designed to meet the secondary school syllabus, and at the same time equipping the students with skills to fit in the modern day global society.

This Book is the Property of the Ministry of General Education and Instruction.

**This Book is not for sale.**

Any book found on sale, either in print or electronic form, will be confiscated and the seller prosecuted.

Funded by:

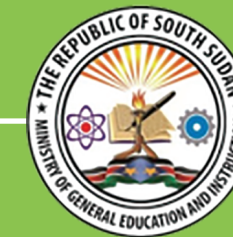

# Secondary Physics 1

Teacher's Guide

Secondary Physics

Teacher's Guide 1

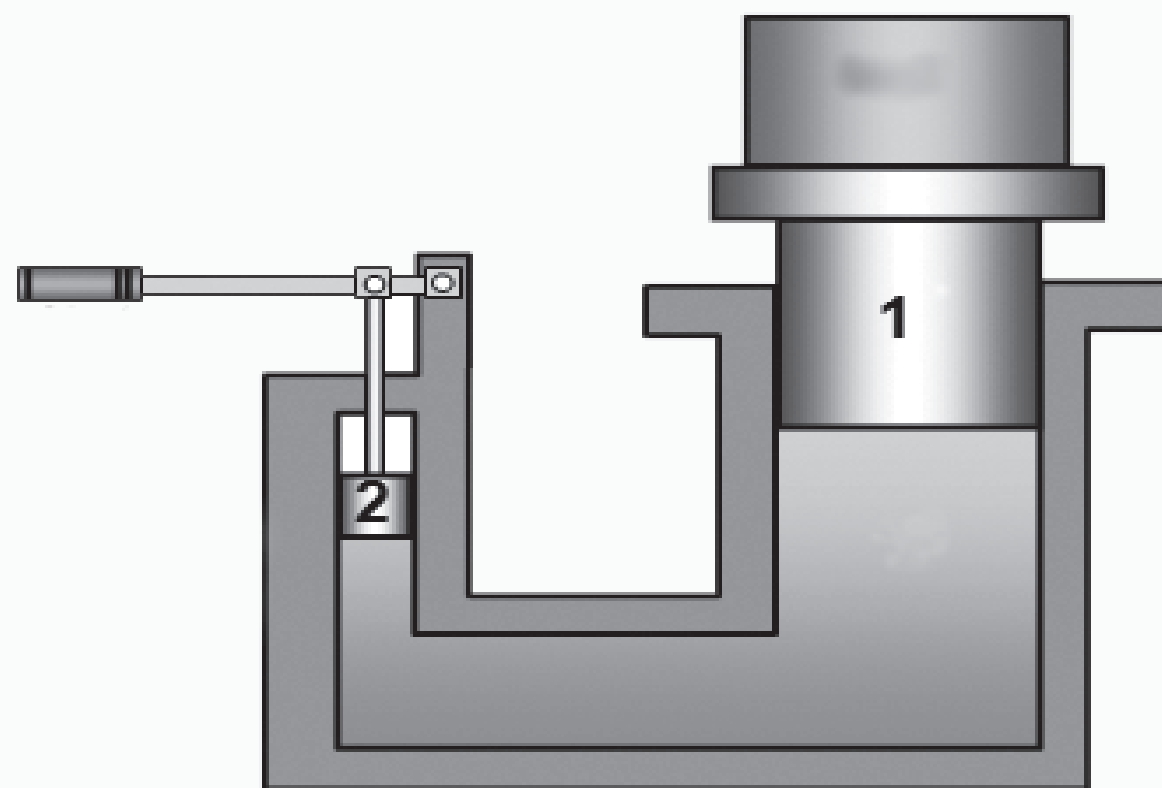

This Book is the Property of the Ministry of General Education and Instruction.

**This Book is not for sale.**

Funded by:



## **How to take care of your books.**

### **Do's**

- 1. Please cover with plastic or paper. (old newspaper or magazines)**
- 2. Please make sure you have clean hands before you use your book.**
- 3. Always use a book marker do not fold the pages.**
- 4. If the book is damaged please repair it as quickly as possible.**
- 5. Be careful who you lend your schoolbook to.**
- 6. Please keep the book in a dry place.**
- 7. When you lose your book please report it immediately to your teacher.**

### **Don'ts**

- 1. Do not write on the book cover or inside pages.**
- 2. Do not cut pictures out of the book.**
- 3. Do not tear pages out of the book.**
- 4. Do not leave the book open and face down.**
- 5. Do not use pens, pencils or something thick as a book mark.**
- 6. Do not force your book into your schoolbag when it is full.**
- 7. Do not use your book as an umbrella for the sun or rain.**
- 8. Do not use your book as a seat.**

South Sudan

SECONDARY

1

# Physics

## Teacher's Guide 1

©2018, THE REPUBLIC OF SOUTH SUDAN, MINISTRY OF GENERAL EDUCATION AND INSTRUCTION.  
All rights reserved. No part of this book may be reproduced by any means graphic, electronic, mechanical, photocopying, taping, storage and retrieval system without prior written permission of the Copyright Holder. Pictures, illustrations and links to third party websites are provided in good faith, for information and education purposes only.



This book is the property of the Ministry of  
General Education and Instruction.

**THIS BOOK IS NOT FOR SALE**

Funded by:



GLOBAL  
PARTNERSHIP  
for EDUCATION

*quality education for all children*

## FOREWORD

I am delighted to present to you this Teacher's Guide, which is developed by the Ministry of General Education and Instruction based on the new South Sudan National Curriculum. The National Curriculum is a learner-centered curriculum that aims to meet the needs and aspirations of the new nation. In particular, it aims to develop (a) Good citizens; (b) successful lifelong learners; (c) creative, active and productive individuals; and (d) Environmentally responsible members of our society. This textbook, like many others, has been designed to contribute to achievement of these noble aims. It has been revised thoroughly by our Subject Panels, is deemed to be fit for the purpose and has been recommended to me for approval. Therefore, I hereby grant my approval. This Teacher's Guide shall be used to facilitate learning for learners in all schools of the Republic of South Sudan, except international schools, with effect from 4th February, 2019.

I am deeply grateful to the staff of the Ministry of General Education and Instruction, especially Mr Michael Lopuke Lotyam Longolio, the Undersecretary of the Ministry, the staff of the Curriculum Development Centre, under the supervision of Mr Omot Okony Olok, the Director General for Quality Assurance and Standards, the Subject Panelists, the Curriculum Foundation (UK), under the able leadership of Dr Brian Male, for providing professional guidance throughout the process of the development of National Curriculum, school textbooks and Teachers' Guides for the Republic of South Sudan since 2013. I wish to thank UNICEF South Sudan for managing the project funded by the Global Partnership in Education so well and funding the development of the National Curriculum, the new textbooks and Teachers' Guides. I am equally grateful for the support provided by Mr Tony Calderbank, the former Country Director of the British Council, South Sudan; Sir Richard Arden, Senior Education Advisor of DfID, South Sudan. I thank Longhorn and Mountain Top publishers in Kenya for working closely with the Ministry, the Subject Panels, UNICEF and the Curriculum Foundation UK to write the new textbooks. Finally, I thank the former Ministers of Education, Hon. Joseph Ukel Abango and Hon. Dr John Gai Nyuot Yoh, for supporting me, in my role as the Undersecretary, to lead the Technical Committee to develop and complete the consultations on the new National Curriculum Framework by 29 November 2013.

The Ministry of General Education and Instruction, Republic of South Sudan, is most grateful to all these key stakeholders for their overwhelming support to the design and development of this historic South Sudan National Curriculum. This historic reform in South Sudan's education system is intended to benefit the people of South Sudan, especially the children and youth and the future generations. It shall enhance the quality of education in the country to promote peace, justice, liberty and prosperity for all. I urge all Teachers to put this textbook to good use.

May God bless South Sudan. May He help our Teachers to inspire, educate and transform the lives of all the children and youth of South Sudan.



Deng Deng Hoc Yai, (Hon.)

**Minister of General Education and Instruction, Republic of South Sudan**

## Table of Contents

<b>Part 1 Introduction .....</b>	<b>1</b>
1.1 Organisation of the book .....	1
1.2 Background information on the new curriculum .....	2
1.3 Basic requirements for an effective Physics lesson.....	6
1.4 Assessment.....	14
<b>Part 2 Topic to topic guide .....</b>	<b>17</b>
<b>Unit 1: The states of matter.....</b>	<b>18</b>
Topic 1: The states of matter.....	20
<b>Unit 2: Types of forces and their measurement.....</b>	<b>32</b>
Topic 2: Introduction to forces.....	36
Topic 3: Pressure.....	52
<b>Unit 3: Effects of temperature on matter.....</b>	<b>64</b>
Topic 4: Effects of temperature on matter .....	66
<b>Unit 4: Behaviour of light at plane surfaces .....</b>	<b>80</b>
Topic 5: Reflection of light on plane surfaces .....	83
Topic 6: Refraction in plane surfaces.....	95
<b>Unit 5:Electricity .....</b>	<b>104</b>
Topic 7: Introduction to static electricity .....	107
Topic 8: Introduction to current electricity .....	111



## 1.1 Organisation of the book

This teacher's guide is organised into two main sections.

**Part 1** is the general **introduction** section detailing information on competence based curriculum and pedagogical issues.

The main elements of Part 1 are:

- **1.2: Background information to the new curriculum** - It gives a brief overview of the general requirements of the new South Sudan competence-based including the guiding principles, the competences the students are expected to acquire, crosscutting issues to be addressed during learning and special needs education.
- **1.3: Basic requirements for an effective Physics lesson**- It highlights the teacher's and learner's roles for effective teaching/learning of Physics, teaching/learning resources, grouping learners for learning and teaching methods

**Part 2** provides a **topic -to- topic guide** to the teacher on how to facilitate learners to acquire the knowledge, skills and attitudes envisaged in each unit. This part is therefore structured into units

The main elements of each unit guide are:

- **Unit heading** – This gives the unit title as stated in the syllabus.
- **Topic heading** – The units have been subdivided (by the authors) into manageable topics.
- **Learning outcomes** – This section outlines *Knowledge and understanding, Skills, Attitudes and values* the learner is expected to achieve through his/her interaction with the concepts and activities planned for the unit.
- **Contribution to student's competences:** The section explains how the unit/topic will facilitate the student to acquire to the specified competences. These competences will be discussed in detail later in the next section.
- **Links to other subjects:** The section explains how the concepts in unit/topic link to other subject areas. This helps the teacher to understand how the unit will help the learner as he interact with facts or concepts in those subject areas, or how the students can transfer knowledge from those areas to help them understand concepts in this unit.

- **Crosscutting issues to be addressed in the unit:** The section outlines the specific crosscutting issues that will be addressed through infusion as the learners do the activities and interact with concepts planned for the unit. This is meant to make the teacher conscious of and be on the look out for suitable opportunities throughout the teaching/learning process in the entire unit to address the cited crosscutting issues. These issues will be discussed in detail later in this section. Note that a unit/topic may not necessarily address all the crosscutting issues outlined in the curriculum.
- **Teaching methodologies:** The section lists down the main teaching/learning methods that the teacher can employ in the unit/topic.
- **Attention to special needs:** The section guides the teacher on how to handle learners with special needs as they do the learning activities organised in the unit.
- **Background information:** This section outlines key knowledge, skills, attitudes and values that learners need to have acquired earlier that will facilitate easier acquisition of the new knowledge, skills, attitudes and values envisaged in this unit. It also guides the teacher on how to find out that the learners possess them before they start learning the concepts in this unit, and how to help learners in case they do not possess them.
- **Subtopics:** This is a list in tabular form of the structuring of the topic into subtopics.
- **Suggested teaching/learning activities:** This section provides guidance to the teacher on how to facilitate students to learn by doing the activities outlined in the student's book. It also guides the teacher on how to assess the learning.

The guidance for each subtopic is structured as follows:

*Subtopic title*

*Specific learning outcome*

*Teaching guidelines for the activity*

*Assessment*

## 1.2 Background Information on the new curriculum

The aim of the South Sudan Competence-based Curriculum is to develop in the learners competences that will enable them interact with the environment in more practical ways. It clearly defines the **knowledge, skills and attitudes** that the learner should acquire by doing the specified learning activities.

### Student's competences

Competencies are statements of the characteristics that students should demonstrate, which indicate they have the ability to do something to the required level of performance.

The following are the four competencies envisaged in this curriculum:



### **(i) Critical and creative thinking**

Physics lessons and activities facilitate learners to acquire these competences by giving them opportunities to:

- Plan and carry out investigations, using a range of sources to find information
- Sort and analyse information and come to conclusions
- Suggest and develop solutions to problems, using their imaginations to create new approaches
- Evaluate different suggested solutions

### **(ii) Communication**

Physics lessons and activities facilitate learners to acquire these competences by giving them opportunities to:

- Read and comprehend critically a variety of types and forms of texts during research activities.
- Write reports on scientific investigations and activities.
- Speak clearly and communicate ideas and science related information coherently.
- Listen and comprehend scientific facts presented by fellow classmates, group members, and teachers and resources persons.
- Use a range of media, technologies and languages to communicate messages, ideas and opinions

### **(iii) Cooperation**

Physics lessons and activities facilitate learners to acquire these competences by giving them opportunities to:

- Work collaboratively towards common objectives when doing activities.
- Be tolerant of others and respectful of differing views, when working together
- Adapt behavior to suit different situations
- Negotiate, respect others' rights and responsibilities, and use strategies to resolve disputes and conflicts
- Contribute to environmental sustainability

### **(iv) Culture and identity**

Physics lessons and activities facilitate learners to acquire these competences by allowing them to

- Take pride in South Sudanese identity and the diverse nature of South Sudanese society.
- Build understanding of South Sudanese heritage in relation to the wider world

- Appreciate and contribute to the development of South Sudanese culture
- Value diversity and respect people of different races, faiths, communities, cultures, and those with disabilities.

### **(b) Cross-cutting issues to be addressed during learning**

These are issues that are of high national priority and hence have been incorporated in the learning process. The three crosscutting issues for that should be addressed through the teaching/learning process are:

#### ***(i) Environment and sustainability***

A well-conserved environment is obviously key to our health and survival. It is therefore important for the Physics teacher to make use of the opportunities that arise in the process of teaching and learning Physics through activities to sensitise learners on the importance of conserving the environment. One way is by ensuring that the learners always dispose off the waste materials at the end of an activity in ways that do not pollute the environment.

#### ***(ii) Peace education***

Peace is critical for a society to flourish and for every individual to focus on personal and national development.

The teacher of Physics teacher needs to be in the fore front in educating his/her students on the need for peace, for example by encouraging group work in the learners activities and showing the them ways of solving peacefully interpersonal problems that occasionally arise during interactions and discussions.

#### ***(iii) Life Skills***

Learners need to progressively acquire some skills abilities and behaviours that will help them effectively deal with the events and challenges of everyday life. Such skills include first aid, communication skills, conflict resolution, basic ICT skills etc. The physics teacher should as much as possible facilitate the learners to acquire these skills whenever an opportunity arises in the lesson execution

### **(c) Special needs education and inclusivity**

All South Sudanese children have the right to access education regardless of their physical and physiological challenges. The physics teacher therefore is required to consider each learner's needs during the teaching and learning process. Assessment strategies and conditions should also be tailored to accommodate the needs of all learners.

The following are the most common categories of special needs in learners:

- Physical challenges
- Visual challenges
- Hearing challenges
- Mental challenges

The teacher should identify such cases and help facilitate the affected learners in learning. For example, learners with visual and hearing difficulties should sit near the teacher's table for easy supervision and assistance. The following are some suggestions on how to support special needs children in your class.

### ***(i) Learners with Physical challenges***

These are learners, who have some of their body parts not able to function normally due to Physical problems. For example, some learners have partial or total incapacitation in the use of limbs or hands. In such cases, the learners will need assistance during activities that involve movement. This could be during field excursions and other activities that learners have to stand for some reason. The teacher should organize for the learner's ease of movement. The learner should also be given time to catch up with the others. In case the hands are affected, the learners should be given more time to finish their work. In both cases, the learners should not be pressurized to do things that can cause injury or ridicule.

### ***(ii) Learners with visual challenges***

These learners have problems with their eyesight. They may be longsighted, short sighted or have some eye sicknesses. They should sit at a position where they are able to see the chalkboard without straining

The material to be observed should be brought to appropriate location where these learners can be able to see. The magnifying glasses can be used where necessary. The teacher should use large diagrams, charts and labels. In some cases, the learners can be allowed to touch and feel whatever they are looking at.

The teacher should read aloud most of the things he/she writes on the chalkboard. Other learners can also assist by reading aloud. The lighting system in the classroom should also be improved.

### ***(iii) Learners with hearing challenges***

The affected part in this case is the ear. The learner can have hearing aids. The teacher should use as many visual aids as possible. They should also project their voice and always talk while facing the learners. The teacher should also use gestures and signs while talking to such learners figure out what he/she is saying.

#### ***(iv) Learners with speech challenges***

One of the most common speech challenges is stammering. Such learners speak with many difficulties. The teacher should be patient with them and encourage them to express themselves in their own way. Such learners should be given more written exercises.

#### ***(v) Learners with mental challenges***

The teacher should identify the nature and level of the mental difficulty with such learners. Such learners should then be given special assistance and attention at individual levels. They can be given special tests or assessments.

In general, all the learners with difficulties should be well facilitated. This encourages and motivates them. The teacher and the rest of the class should never ridicule learners with any of the difficulties. Note that generally, the people with any kind of disability can be very sensitive to any kind of negative comments or criticism.

*Remind them that ‘Disability is not inability’.*

Treat them fairly but not with undue favours.

### **1.3: Basic requirements for an effective Physics lesson**

#### **1.3.1 Teacher’s role and basic skills for effective Physics lesson**

The teacher is the most important resource for an effective Physics lesson.

##### **(a) Some of the key roles of the Physics teacher include:**

- Organising the classroom to create a suitable learning environment.
- Preparing appropriate materials for learning activities.
- Engaging students in variety of learning activities.
- Encouraging and accepting student autonomy and initiative.
- Allowing student responses to drive lessons, shift instructional strategies,.
- Familiarizing themselves with students’ understandings of concepts before sharing their own understandings of those concepts.
- Encouraging students to engage in dialogue, both with the teacher and one another.
- Engaging students in experiences that pose contradictions to their initial hypotheses and then encouraging discussion.
- Providing time for students to construct relationships and create metaphors.
- Using a variety of teaching and assessment methods.
- Adjusting instructions to the level of the learner.

- Nurturing students' natural curiosity.
- Motivating learners to make them ready for learning.
- Coordinate learners' activities so that the desired objectives can be achieved.
- Assessing learners' activities and suggest solutions to their problems.
- Assist learners to consolidate their activities by summarising the key points learnt.

**(b) Some of the key skills that the S3 Physics teacher should have include:**

- Creativity and innovation.
- Makes connections/relations with other subjects.
- A high level of knowledge of the content.
- Effective disciplining skills manage adequately the classroom
- Good communicator.
- Guidance and counselling.

### **1.3.2 Learner's role in learning Physics**

Learning takes place only when the learner acquires the intended knowledge, skills and attitudes. As such, learning is a highly personal and individual process. Thus, a learner must be actively engaged in the learning exercise.

For active participation in learning, the learner should:

- Raise questions about what is observed.
- Suggest solutions to the problems observed.
- Take part in planning investigations with appropriate controls to answer specific questions.
- Carry out investigations to search for answers with the help of materials in search of patterns and relationships while looking for solutions to problems.
- Working collaboratively with others, communicating their own ideas and considering others' ideas.
- Expressing themselves using appropriate Physics terms and representations in writing and talk.
- Engaging in lively public discussions in defence of their work and explanations.
- Applying their learning in real-life contexts.
- Reflecting critically about the processes and outcomes of their inquiries.

### 1.3.3: Teaching/learning resources

These refer to things that the teacher requires during the teaching process. They include:

- The classroom
- Textbooks
- Wall charts and wall maps
- Materials and apparatus
- Various tools and equipment
- Physics models
- Resource persons
- Firms such as hydroelectric power stations, engineering firms among others

#### (a) Classroom as a learning environment

A Classroom generally refers to the place where learning takes place. Learners learn from everything that happens around them, such as the things that they hear, see, touch, taste, smell and play with.

#### *Classroom organization*

It is important for the teacher to make the classroom an attractive and stimulating environment. This can be done by:

- Carefully arranging the furniture in the classroom in an organised way. to allow free movement of learners and the teacher.
- Putting up learning and teaching aids on the walls. Examples are wall charts, pictures and photographs.
- Displaying teaching models.
- Providing objects for play for example toys.
- Having a display corner in the classroom where learners display their work.
- Setting a corner for storing materials so as not to obstruct learners or distract them.
- Spreading out the learners evenly so that they do not interfere with one another's activities.
- Setting up the materials for the series of lessons or activities going on for a number of days or weeks in a location where they do not interfere with other daily activities
- Organizing the sitting arrangement such that learners face the lighted areas of the room.
- Choosing the most appropriate location for the teacher and the chalkboard such that they are visible to all learners and the teacher has a good view of all learners in the class.

## **(b) Apparatus and materials**

For learners to study Physics through the activity method, a number of materials and apparatus are required. The important role played by materials in learning has been felt for centuries. This is noted for instance in the old Chinese proverb that says:

- *When I hear I forget*
- *When I see I remember*
- *When I do I understand*

Since Physics is highly practical subject, materials help the teacher to convey his/ her points, information or develop skills simply and clearly, and to achieve desired results much faster.

Some of the materials that a teacher requires for Physics activities and calculations can be collected from the local environment.

Many others can be improvised while some have to be purchased. Whether collected, improvised or purchased, there are certain materials that are valuable to have around almost all the time.

These include:

### ***(i) Science Kit***

A science kit is a special box containing materials, apparatus and equipment necessary to conduct an array of experiments. The content of the physics kit depends on the curriculum requirements per level. Most science kits are commercially available and target particular levels of learners. However, the teacher is encouraged to come up with a kit based on the syllabus requirement

### ***(ii) Models***

A model refers to a three-dimensional representation of an object and is usually much smaller than the object. Several models are available commercially in shops. Examples of Physics models include models of electric motors, hydraulic systems among others. Schools for use can purchase these models during Physics activities.

### ***(iii) Resource persons***

A resource person refers to anybody with better knowledge on a given topic area. Examples include health practitioners such as doctors, nurses and laboratory technologists, agricultural extension officers, environmental specialists among others. Depending on the topic under discussion, the teacher can organize to invite a resource person in that area to talk to learners about the topic. The learners should be encouraged to ask as many questions as possible to help clarify areas where they have problems.

#### ***(iv) Improvisation***

If each learner is to have a chance of experimenting, cheap resources must be made available. Complicated apparatus may not always be available in most schools. Such sophisticated equipment made by commercial manufacturers are usually expensive and majority of schools cannot afford them. The teacher is therefore advised to improvise using locally available materials as much as possible.

#### ***(vi) Scheduling learning activities and venues***

Some of the activities suggested in the student's good planning and scheduling in order to get accurate results. An example is observing some effects of environmental factors on plant growth illustrated in unit 14. The teacher should therefore think ahead while making the scheme of work so that the prevailing weather pattern and the most appropriate timing are considered..

### **1.3.4 Grouping learners for learning activities**

Most of the Physics activities suggested in the student's book are carried out in groups and therefore the teacher should place 2 or 3 desks against each other and then have a group of learners sitting around those desks.

In certain activities, the teacher may wish to carry out a demonstration. In this case, the learners should be sitting or standing in a semicircle, or arranged around an empty shape of letter "U" such that each learner can see what the teacher is doing clearly and without obstruction or pushing. If the learners are involved in individual work, each learner can work on the floor or on the desk or a portion of the desk if they are sharing. In this case, they need not face each other.

Grouping learners for learning has increasingly become popular in recent years. In fact, the shift from knowledge-based to competence curriculum will make grouping the norm in the teaching process.

**Learning grouping** can be formed based one or a number of the following considerations:

- Similar ability grouping
- Mixed ability grouping
- Similar interests grouping
- Common needs grouping.
- Friendship grouping.
- Sex-based grouping.



Grouping learners in a Physics class has several advantages that include:

- The individual learner's progress and needs can easily be observed.
- The teacher-learner relationship is enhanced.
- A teacher can easily attend to the needs and problems of a small group.
- Materials that were inadequate for individual work can now be easily shared.
- Learners can learn from one another.
- Cooperation among learners can easily be developed.
- Many learners accept correction from the teacher more readily and without feeling humiliated when they are in a small group rather than the whole class.
- Learners' creativity, responsibility and leadership skills can easily be developed.
- Learners can work at their own pace.

The type of "grouping" that a teacher may choose may be dictated by:

- The topic or task to be tackled.
- The materials available.
- Ability of learners in the class (fast, average, slow).
- Class size

There is no one method or approach to teaching that is appropriate to all lessons. A teacher should, therefore, choose wisely the method to use or a combination of methods depending on the nature of the topic or subtopic at hand.

### **1.3.5: Teaching methods**

There are a variety of possible methods in which a teacher can help the learners to learn. These include:

- (a) Direct exposition
- (b) Discovery or practical activity
- (c) Group, class or pair discussion
- (d) Project method
- (e) Educational visit/ field trips
- (f) Teacher demonstration
- (g) Experimentation/Research

The particular technique that a teacher may choose to use is influenced by several factors such as the:

- Particular group of learners in the class.
- Skills, attitudes and knowledge to be learned.
- Learning and teaching aids available.
- Local environment.
- Teacher's personal preference
- Prevailing weather condition.
- Requirements of Physics syllabus

***(a) Direct exposition***

This is the traditional way of teaching whereby the teacher explains something while the learners listen. After the teacher has finished, the learners may ask questions. However, in a competence-based curriculum, this technique should be used very minimally.

***(b) Guided Discovery***

In this technique, the teacher encourages learners to find out answers to problems by themselves. The teacher does this by:

- Giving learners specific tasks to do.
- Giving learners materials to work with.
- Asking structured or guided questions that lead learners to the desired outcome.

Sometimes learners are given a problem to solve and then left to work in an open-ended manner until they find out for themselves.

This is the most preferred method of teaching in the implementation of competency-based curriculum.

***(c) Group/class discussion or pair work***

In this technique, the teacher and learners interact through question and answer sessions most of the time. The teacher carefully selects his/her questions so that learners are prompted to think and express their ideas freely, but along a desired line of thought. The method leads learners from the known to unknown in a logical sequence; and works well with small groups. The method boosts confidence in learners and improve interpersonal and communication skills.

The main disadvantage of this method is that some learners maybe shy or afraid to air their opinions freely in front of the teacher or their peers. It may give them more confident learners a chance to dominate the others.

***(d) Project method***

In this approach, the teacher organizes and guides a group of learners or the whole class to undertake a comprehensive study of something in real life over a period of time such as a week or several weeks.

Learners using the project method of studying encounter real life problems, which cannot be realistically brought into a normal classroom situation. A project captures learners' enthusiasm, stimulates their initiative and encourages independent enquiry. The teacher, using the project method, must ensure that the learners understand the problem to be solved and then provides them with the necessary materials and guidance to enable them carry out the study.

The main disadvantage of this method is that if a project is not closely supervised, learners easily get distracted and therefore lose track of the main objective of their study. Studying by the project method does not work well with learners who have little or no initiative.

***(e) Educational visits and trips/nature walks***

This is a lesson conducted outside the school compound during which a teacher and the learners visit a place relevant to their topic of study. An educational visit/nature walk enables learners to view their surroundings with a broader outlook that cannot be acquired in a classroom setting. It also allows them to learn practically through first-hand experience. In all “educational visit/nature walk lessons”, learners are likely to be highly motivated and the teacher should exploit this in ensuring effective learning. However, educational visits are time consuming and require a lot of prior preparation for them to succeed. They can also be expensive to undertake especially when learners have to travel far from the school.

***(f) Demonstration lessons***

In a demonstration, the teacher shows the learners an experiment, an activity or a procedure to be followed when investigating or explaining a particular problem. The learners gather around the teacher where each learner can observe what the teacher is

doing. It is necessary to involve the learners in a demonstration, for example by:

- Asking a few learners to assist you in setting up the activity.
- Requesting them to make observations.
- Asking them questions as you progress with the demonstration.

This will help to prevent the demonstration from becoming too teacher-centred.

### ***When is a demonstration necessary?***

- A teacher may have to use a demonstration, for example when:
- The experiment/procedure is too advanced for learners to perform.
- The experiment/ procedure is dangerous.
- The apparatus and materials involved are delicate for learners to handle.
- Apparatus and equipment are too few.

## **1.4 Assessment**

### **What is assessment?**

“Assessment is the process of gathering and discussing information from multiple and diverse sources in order to develop a deep understanding of what students know, understand, and can do with their knowledge as a result of their educational experiences; the process culminates when assessment results are used to improve subsequent learning.

### **Categories of assessment**

There are two categories of assessment:

- Formative assessment
- Summative assessment

### **Formative assessment**

Formative assessment refers to the range of formal and informal assessment procedures undertaken by teachers in the classroom as an integral part of the normal teaching and learning process in order to conduct in-process evaluations of student comprehension, learning needs, and academic progress during a lesson, unit, or course. B Therefore, formative assessment is diagnostic as opposed to evaluative.

The feedback obtained through formative assessment helps the teacher to:

- Gauge learners’ progress, achievement and learning needs; and make immediate intervention to intervene to improve student attainment.

- Modify the teaching activities and instruction in order to enhance learners' achievement of learning objectives.

**Opportunities for formative assessment occur in three forms.**

Dr Anne Davies (Making Classroom Assessment Work 2011) called these three forms:

- **Observation** – watching students working (good for assessing skills)
- **Conversation** – asking questions and talking to students (good for assessing knowledge and understanding)
- **Product** – appraising the student's work (writing, science report, math calculation, presentation, map, diagram, model, drawing, painting etc). In this context, a “product” is seen as something physical and permanent that the teacher can keep and look at, not something that the student says.

When all three are used, the information can be checked against the other two forms of assessment opportunity. This is often referred to as “triangulation”.

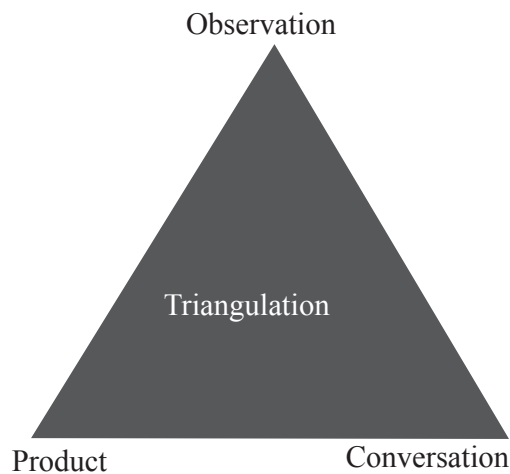

*Triangulation of assesment opportunities*

These opportunities can be found in the “Learn About’ sections of each syllabus unit. The section describes the learning that is expected and in doing so, it set out a range of opportunities for the three forms of opportunity.

**Summative assessment**

This type of assessment is carried out at the end a defined instructional period like a project, unit, course, semester, program, or school year to evaluate the student's acquisition of knowledge and skills, academic achievement; and evaluate the effectiveness of

educational programs, measure progress toward improvement goals, or make course-placement decisions, among other possible applications.

The students achievement is compared some standard or benchmark.

- Examples of formative assessment include:
- End-of-unit or chapter tests.
- End-of-term or semester tests.
- Standardized tests
- Final projects

Summative-assessment results are usually recorded as scores or grades into a student's permanent academic record e.g. a report card or test scores used in the college-admissions process.

## **Part 2** Topic to topic guide

---

# UNIT 1

## States of matter

### Topics in the unit

#### Topic 1: States of matter

Learn about		Key inquiry Questions
<p>Learners should investigate the macroscopic properties of matter and classify them into solids, liquids and gases and understand that the state of a substance depends on temperature, and a change in temperature can cause a substance to change state. They should research evidence to support the claims of the particle theory, which infer that all substances are made up of particles, that are moving, and there are spaces between the particles that in gas are relatively large while in solids and liquids they are relatively small. Using the particle theory they should explain the expansion and contraction of substance, the greater densities of solids when compared with liquids or gases and, be able to relate the different densities of hot and cold air to particle spacing. They should investigate the particle theory in terms of Surface tension, adhesion and cohesion, capillary attraction, osmosis, fluid friction.</p>		<p>How can we explain why matter exists in three states?</p> <p>How do the forces interact in matter?</p> <p>What causes the change of states of matter?</p> <p>How could we determine the viscosity of a certain fluid in the lab?</p>
Learning Outcomes		
Knowledge and Understanding	Skills	Attitudes
<p>Understand that matter can exist in different states</p>	<p>Perform tests to investigate surface tension, osmosis and capillarity of fluids.</p> <p>Predict what might happen based on the particle theory</p> <p>Use appropriate measures</p> <p>Collect and present results appropriate</p> <p>Interpret results accurately</p> <p>Report findings appropriately</p>	<p>Show curiosity in carrying experiments.</p>



## **Contribution to student competencies**

- **Critical thinking:** This topic gives the learners a variety of activities that they should work out and deduce the outcomes. They should think critically to answer some questions in the activities for instance when they are asked explain the composition of matter. Are the learners able to explain the three states and how one can be able to change matter from one state to another? Are they able to relate what they are learning to the observation they make in their day-to-day activities e.g. when boiling water?
- **Co-operation:** As the learners are doing the activities they should be able to work collaboratively and harmoniously so as to help each other in the learning process. Encourage them to take turns when discussing the different concepts e.g. when describing matter, each one in the group should be allowed to make his or her own contribution.

## **Links to other subjects**

- **Biology ecology:** Help the learners appreciate the links between what they are learning in this topic with biology. They should note that the different states of matter have different effects on survival of living things. Animals in ice land are able to survive on the ice by developing thick skin.
- **Geography in environment,** the learners should be able to associate the change of states of matter to formation of rain. They should also relate the different states of matter to the climate change.
- **Chemistry chemical:** Help the learners understand the effect of change of state to chemical reactions. They will use this knowledge to understand why certain chemicals can react in liquid state but not in solid state.

## **Cross cutting issues addressed in this unit**

**Environment, climate change and sustainability:** This topic will help enrich the learner's discussion on environment conservation measures. For instance, activity 1.13 discusses about polythene bags and their effects in the environment. They should be disposed properly and recycled where necessary.

## **Attention to special needs**

- Ensure that the learners with disabilities are well taken care of and they are participating in the class activities. The learners who may be handicapped could actively participate in the discussion of the observation made in the activities. Encourage other students to form groups with them reminding them that disability is not inability.
- Those with visual impairment should seat in front of the class where they can be able to see the black board with ease. Incase there are learners who use wheelchairs you should ensure that the class is well organized for heir easy mobility.

(Student's book pages 2-28)

### Background information and / or prior knowledge

- Learners have come across matter in their daily lives and they always interact with matter. In this topic we will explore the states of matter and then look at the kinetic theory of matter. Use the learner's daily experience with interaction with matter to build and help them understand the different concepts in this topic. This should be an interesting topic to the learners as they scientifically explain the different concepts they come across in their daily life.

### Subtopics

No.	Subtopics
1.1	Matter and its composition
1.2	Introductions to kinetic theory
1.3	Physical properties of matter
1.4	Movement of particles in matter
1.5	Applications of adhesive and cohesive forces
1.6	Surface tension

### Suggested teaching/learning activities

#### 1.1 Matter and its composition

#### Specific learning outcome

*By the end of this section the learners should be able to define matter and state its composition.*

#### Teaching guidelines for activity 1.1

- The learners should complete this activity without referring to the textbook. This will help you assess how much they can recall what they had learned in primary.
- Are they giving the relevant examples for the activity? Can they be able to note that examples of matter are precisely anything they can see and touch?

- Ensure that they are able to take turns to discuss different examples of matter, so that each learner is able to sharpen his communication skills as well as listening skills as they discuss.

### **Teaching guidelines for activity 1.2**

- As the learners are breaking the pieces of paper into smaller particles, ask them to explain why they are able to keep cutting the piece of chalk or paper into smaller pieces? Is there a possibility of getting smaller pieces than the smallest pieces they got? What is the building block of matter from their observation? Can matter be build from different particles?
- Can they note that different methods are used to separate different mixtures?
- Encourage the learners to analyze the different concepts and think critically for them to be able to answer the questions in the activity.

### **Assessment opportunities**

#### ***Observation***

This is an activity that requires simple materials to perform. Ensure that each learner is doing the activity before they start discussing in their groups. Is each learner in the group able to make a contribution in the discussion? Can they use the conclusion they have made from the observation to explain the difference between an element and a compound?

#### ***Conversation***

As the learners are discussing go round each group and ensure that that they are doing the right thing. Are they able to discuss constructively? As the learners are discussing in their groups, guide them so that the responses they make are likely to engage them to come up with the composition of matter.

(They don't have to be right at this moment but encourage them to think and give some solutions.)

#### ***Product***

Check the examples that the learners have given. Have they given the correct examples of matter? Are they able to give valid reasoning on the components of matter? Guide them to arrive at the correct reasons.

## 1.2 Introductions to kinetic theory

### Specific learning outcome

*By the end of this section, the learner should be able to demonstrate motion of matter and the components of matter that are in continuous motion.*

### Teaching guidelines for activity 1.3

- Ask them to pour water in a beaker to more than half way and allow it to settle. Let them drop crystals of potassium permanganate into the water in the beaker and observe what happens. Ensure that they use a glass tube or a straw to deliver the potassium permanganate into the water so they can be able to clearly see as the colour spreads. What do they note about the color of the water? Are they able to state that if water is not allowed to settle the color spreads quickly? Ask them why they think this happens.
- When they heat the water, what do they note about the speed at which the color of the water changes? Can they be able to deduce and compare the difference between when heat is applied and when its not?
- Before the learners perform this part ensure they remove all sources of airflow from the room. Close all windows and turn off all fans, including the AC fan. Exact times may differ between individuals because each person's nervous system reacts to smells at different concentrations.
- Ask one student in the classroom to go into the corner in front of a class with a perfume and spray it.
- Ensure the learners stand in one row from the corner the perfume is sprayed. Let each raise the hand whenever he feels the smell of the perfume. Are the learners able to explain that the smell of the perfume spreads from the corner it is sprayed to other parts of the class?
- Can they explain what happens when the perfume is sprayed in one corner to make it spread to the other corner? Is the strength of the smell the same in every corner of the class? Why?

### Assessment opportunities

#### *Observation*

- As the learners are raising their hand as the spray spreads across the room ensure that they closely note the pattern in which they raise their hands, as the smell may spread quickly.

- Observe as the learners are discussing the activity. Are they able to explain why they are able to smell the spray in every corner? Can they relate the concept of the spray to the kinetic theory of matter?

### **Conversation**

As the learners are discussing go round each group and ensure that they are doing the right thing. Listen to the learners as they are stating the theory; are they able to use the scientific terms to explain the theory? Are they able to note the assumptions of the theory?

What will happen if the temperature of the room was changed?

### **Product**

Let each learner close the textbook and note down the kinetic theory of matter in their own understanding. They should also list the assumptions made by the theory. Ask them to exchange books with their partners and look at each other's work. Have their partners written the correct form of the theory? Help them guide each other in correcting any errors they may have in their work this helps them improve their communication and listening skills as they guide each other. They will also help the slow learners to understand the concept better.

## **1.3 Physical properties of matter**

### **Specific learning outcome**

*By the end of this section the learner should be able to state and explain the physical properties of the three states of matter.*

### **Solids**

#### **Teaching guidelines for activity 1.4**

- If there is no Internet the learners can do research from resource persons. Even though the information given in the learner's book can help in the research, it is important that the learners also use other sources so that they can compare the information they get.
- The learners can also use small fruits in place of marbles.
- Ensure that members in each group are mixed up and each member should participate actively in the group. Prompt them to realize that they need a group leader and secretary who will record the group's findings. Each member should also have a role in the group; this helps them develop leadership skills.

- Guide them to do a research on the properties of solids and their applications from Internet or reference books. Are they able to note the correct physical properties? In case the learners are getting their information from resource persons they should be able to internalize the information and make notes according to their understanding.
- As they put the marbles in the container, ask them if they are able to notice the pattern (arrangement) of the marbles in the square bowl and then draw it on a notebook. Are they able to relate the arrangement of the marbles in the container with the arrangement of the particles in solids?
- Let the learners put different solid shapes into a bigger container. Do the shapes change? What keeps the solid particles packed up together?
- These activity will promote in a learner;
  1. Communications skills through expression of their opinion in the group discussion.
  2. Critical thinking through answering questions critically.

### **Assessment opportunities**

#### ***Observation***

Observe as the learners are discussing the activity. Are they able to state the properties of solids? What keeps the solid particles together? What shape does the solids take and why they take that given shape?

#### ***Conversation***

As the learners as they are discussing go round each group. Guide them to note the properties of solids. Are they able to explain the properties of solids correctly? Giving learners time to express their points in class helps them build their oral skills as well as their self-confidence.

### **Liquids**

#### **Teaching guidelines for activity 1.5**

- Let the learners put some chalk dust in a beaker of water. Guide them to put the chalk dust slowly in water so that they are able to note that it is not the disturbance when they put the dust in water that causes them to move. Are they able to note the movement of the chalk particles? What causes the chalk particles to move?
- Give them an opportunity to present their observations. Evaluate each reason given by the learners to ensure that they are able to explain what causes the particles to move.

- As they heat the water until it boils while they still observe the motion of the chalk particles, are they able to explain scientifically why the speed of the particles change?
- As the learners explain the reasons, they are able to develop oral skills. The other learners are able to develop listening skills as they listen to the one who is presenting.

### **Teaching guidelines for activity 1.6**

- In this activities the learners can use containers of different shapes and not necessarily a beaker and a conical flask. The main concept that they should arrive at is that liquids don't have a definite shape thus they take the shape of a container.
- Are the learners able to explain why the liquid takes the shape of the container? What can they state about the molecules of the liquid as compared to those of solids? Give the learners an opportunity to debate the reasons they have stated with other groups so that they can come up with more harmonious reasons.
- How can they compare the forces holding liquid molecules to those holding solid molecules? Can they be able to comment on the density of liquids in comparison to the density of solids?

### **Assessment opportunity**

#### ***Observation***

Observe as the learners are discussing the activity. Are they able to follow the instructions of the activities? Can they be able to discuss constructively and come up with the properties of liquids?

#### ***Conversation***

As the learners are discussing go round each group. Guide them to note the properties of liquid? Prompt them to use the kinetic theory of matter to explain the movement of the chalk particles in the water.

In case they don't give accurate reasons, let them know that the particles or molecules of liquids move freely and randomly.

### **Teaching guidelines for activity 1.7**

- Ensure that they are taking the right readings from the thermometer. Ensure the learners have dipped the thermometer into the liquid, as this is a common error when taking the reading from a thermometer. They should keep stirring the water to ensure even distribution of heat. You should caution them as they stir to do it carefully so they don't break the thermometer. This will also help the learners not to splash hot

water on themselves and other group members.

- Are the learners able to observe the changes in the water particle movement as the temperature increases? How can they explain this concept? What makes the water boil vigorously?

### **Assessment opportunity**

#### ***Conversation***

As the learners are discussing go round each group. How do they explain why the water boils vigorously? Are they able to explain what happens to the temperature as the water boils?

How can they explain the concept of boiling point in their own understanding?

### **Gases**

#### **Teacher's guidelines for activity 1.8**

- Let the learners to do research on the physical properties of gases from the internet or resource person
- Are the learners able to identify the physical properties of gases?
- Ask them to put 3 marbles in a transparent dish, and try to move them separately from each other as possible and then cover it with a lid. Can they be able to relate the distance of the marbles and the distance of the gas molecules?
- How do the distance of gas molecules compare to that of liquids and solids? What causes this difference?
- As they shake the marbles, can they be able to relate the movement of the marbles to the movement of the gas molecules?

#### **Teacher's guidelines for activities 1.9 and 1.10**

- Ask the learners to pick a polythene bag and make a small hole where they will insert in a straw from leaving it to protrude and then seal it with a cello tape.
- Let them put a book on top of the polythene bag and in turns let them blow it into the bag. What causes the polythene bag to increase in size?
- Let them sketch the arrangement of particles in gases.
- When they are done with a activity 1.9 ask them to do activity 1.10
- What happens to the solid carbon dioxide? Why is it possible for the fumes carbon dioxide to move and fill both tumblers? Can they be able to explain what would happen if bigger containers was used?



## Assessment opportunity

### Conversation

- As the learners are discussing go round each group. Guide them to note the properties of gases. Can they be able to relate what they are doing to what happens with the molecules of gases? How do properties of gases compare to those of liquids and solids? Can the learners use the properties of gases to compare the density of gases to that of liquids and solids?
- Using the properties they have discussed can they be able to explain why gases are compressible while solids are not?

## 1.4 Movement of particles in matter

### Specific learning outcome

*By the end of this section the learners should be able to state and explain the different kinds of movements in matter.*

### Teacher's guidelines for activity 1.11

- Provide the learners with liquids of different viscosity.
- As the learners observe the flow of the different liquids, are they able to note the difference in their flow? If they may not be able to make the observation as they pour the liquids, they can pour equal amounts of each liquid on a flat surface and observe which liquid flows the furthest within a short period. Are they able to explain how viscosity makes the liquids have different flow rates?
- Ask them, to conclude the liquid in which the sphere moved very fast and if it has a low viscosity or high viscosity. Ask them from their knowledge of viscosity to explain the observation they have made.

## Assessment opportunity

### Conversation

As the learners are discussing go round each group. Are they able to note the difference in viscosity among the liquids? How can they explain what causes the sphere to move at different rates in the different liquids?

It is important to inform the learners that they will learn much more on viscosity in secondary 3.

## **Product**

Look at the table the learners have filled, is the table giving a true picture on viscosity of the different liquids? What interpretation can they give from the data they have collected?

## **Diffusion**

### **Teaching guidelines for activity 1.12 and 1.13**

- Organize learners into appropriate groups, if the class is mixed, ensure you have the gender balance (i.e., equally number of boys and girls, if possible) and also they are of different abilities (slow and gifted learners). This will help learners to appreciate the fact that all students (whether boys or girls) should be given equal opportunity to learn and also to promote the sharing of ideas and cooperation among themselves.
- Let the learners put colored water or a solution of potassium permanganate in a bottle and submerge the bottle in clean water. The opening of the bottle should not be closed. Ask them to explain why the color spreads through the clean water. Ensure that the bottle of colored water is fully submerged in the clean water. Does the explanation they give show the idea of diffusion?

### **Teaching guidelines for activity 1.13**

- The learners can use a universal indicator in case there is no litmus paper. You can also advise them to use both blue and red litmus paper so that they can easily see that the gas only has effect on the blue litmus paper.
- If there is no supply of carbon dioxide in the school you can prepare for the class by reacting calcium carbonate and hydrochloric acid and collect the gas for the learners to use.
- Instead of all learners doing the activity in individual groups you can do the activity as the learners observe and then ask them to discuss and write their conclusion for the activity.
- Ask the learners to explain how diffusion takes place in gases. Are they able to relate diffusion in gases to an instance in their daily life?
- Let them explain what the effect of using gases of different masses would be. Will they diffuse at the same rate? Why is this so?

## **Assessment opportunity**

### ***Observation***

Observe as the learners are discussing the activities. Are they able to follow the instructions

of the activities? How are they explaining how diffusion takes place? Is every learner participating actively in the activity?

### ***Conversation***

As the learners are discussing go round each group. Are they able to explain what diffusion is from the observation they have made? How do they explain diffusion? Are they using the right scientific terms?

### ***Product***

Check the investigation procedure the learners have indicated, does their procedure have a chronological flow? Can they be able to get the results from their investigation?

Have they noted down the correct formula to illustrate Graham's law?

## **Osmosis**

### **Teaching guidelines for activity 1.14**

- Help the learners to tie the visking tubing with one side tied to a capillary tube. Let them ensure that the solution in the visking tubing has a high concentration.
- Evaluate the observations the learners are making. Are they able to note that there is rise in level of solution in the capillary tube? Can they be able to explain why the rise is observed?

### **Assessment opportunity**

### ***Conversation***

As the learners are doing this activity in groups, check and evaluate if they are able to explain how osmosis takes place? What is the difference between osmosis and diffusion? Can they be able to explain how the rate of osmosis can be increased or reduced?

## **1.5 Applications of adhesive and cohesive forces**

### **Teaching guidelines for activity 1.15**

The mercury is very dangerous to learners so it's important that you do the activity as the learners observe.

Alternatively you can make a drawing on a chart to represent the capillary action in water and in mercury and let the learners identify each of them.

## Assessment opportunity

### *Observation*

Observe as the learners are discussing the activity. Are they able to follow the instructions of the activities?

### *Conversation*

As the learners are discussing go round each group. Are they able to note that the water molecules move from a region of low concentration to a region of high concentration?

They should note that:

- The forces of attraction between molecules of the same substance called cohesive force. Intermolecular forces between molecules of different substances called adhesive force
- Capillary action has a lot of applications in real life including; rising up of kerosene in lamps and the rise of minerals from the soil up the stem of plants.

## 1.6 Surface tension

### Teaching guidelines for activity 1.17 and 1.18

- Ask the learners to put water in a beaker and allow it to settle down. Let them put a tissue paper in the water and observe what will happen.
- Guide them to place a small pin slowly and carefully on top of the tissue and observe what happens. Some learners may have difficulties placing the pin perpendicularly on the tissue; this may result in the pin sinking thus making the wrong observation. It is important that you help them.
- Activity 1.18 is another good activity that illustrates surface tension. It goes further to show that liquids tend to have surface tension as small as possible.
- Let them dip a filter funnel in a liquid soap or a detergent solution; they should then blow a bubble at the wider end and observe how it behaves. Are they able to note that the film slowly moves up the funnel to the narrowest end of the funnel?

### *Conversation*

- Are they able to know that the cohesive forces among liquid molecules are responsible for the phenomenon of surface tension? In the bulk of the liquid, each molecule is pulled equally in every direction by neighbouring liquid molecules, resulting in a net force of zero.

### Teaching guidelines for activity 1.19 and 1.20

- Ensure that the cotton thread the learners are using is thin and flexible so as to well illustrate the concept.
- Let them dip the wire frame into the liquid soap or detergent solution as they observe what happens. Are they able to note that once the film is broken it forms a perfect circle?

### Assessment opportunity

#### Product

Ask the learners to work out exercise 1.1 in the learner's book. Let them exchange their book in class. Guide them through the exercise as they check each other's work.

#### Additional activities

1. **Suggested materials:** beaker, provision for tap water, hand lens and a bright source of light (if the day is not bright and sunny).

Collect fresh tap water in a beaker and focus sunlight on to the beaker. You can 'see' the movement of the suspended particles of solid matter. The water molecules are moving at random inside the beaker. Though the solid dust particles have a tendency to settle down, the water molecules moving at random collide with these solid particles and force them to move in a haphazard manner.

2. **Suggested materials:** Toothpaste, glass slide and cover slip (can be collected from the biology laboratory), powerful source of light, a microscope and water.

Take a small trace of toothpaste mixed in water on a microscope slide and place a cover slip over the slide. Illuminate the slide with concentrated light from the side and observe the top with a powerful microscope. Concentrate on one tiny particle. Though the particle seems to be stationary in one position first, eventually you can see the random motion of the molecules of paste in the mixture, being displaced continuously in all the directions

As the molecular structure concept in gases, solids and liquids has been well established, the teacher should tell the students to draw a table and compare the spacing, ordering and the movement of the molecules in the three states of matter.

#### Answers

For non-numerical questions, the learners can get most of the answers from the discussions given in student's book or from the Internet and any other reference books. Mark the student's work and use it to guide them appropriately.

## UNIT 2

# Types of forces and their measurement

### Topics in the unit

Topic 2: Introduction to forces

Topic 3: Pressure

Learn about:	Key inquiry questions
<p>Learners should know that force can be a push or a pull. Forces can change the speed of something, the direction it is moving in or its shape. Forces can be measured using a force meter and unit of force is newton (N). Learners should carry out practical investigations to help them understand that weight, which is a force, and is measured in newtons and mass is measured in kilograms (kg) or grams (g). The mass of an object is the amount of matter it contains and the more matter an object contains, the greater its mass</p> <p>Learners should know that gravity is a force that attracts objects each. Gravitational force increases when the masses are bigger and the objects are closer, and the gravitational force pulls towards the center of the Earth. Weight is a force caused by gravity and can be affected by the force of friction. The more mass the object has the greater its weight will be. The mass of an object stays the same wherever it is, but its weight can change.</p> <p>Learners should carry out practical investigations using meters into the effect of friction and pressure calculated by the force or weight applied divided by the area over which the force or weight works so <math>\text{pressure} = \text{force} \div \text{Area}</math>.</p>	<p>How do we classify forces?</p> <p>How can we distinguish between weight and mass of a body?</p> <p>Why are frictional forces are importance to an object?</p>

Learning Outcomes		
Knowledge and Understanding	Skills	Attitudes
Understand the types of forces and their measurement.	Carry out practical investigations using meters into the effect of friction and pressure Use appropriate measures Collect and present results appropriately Interpret results accurately Report findings appropriately	Show curiosity in carrying out experiments.

## Contribution to student competencies

### 1. Cooperation

During group discussions and pair works - let learners engage one another by giving a chance for all to participate .You can also allow rotational presentations within the group members. Further, encourage learners to be tolerant to other learner’s views and to understand that people should not necessarily be always right.

**REMEMBER:** You should allow slow learners to do presentations as well and correct them where they go wrong. Further, Advise learners to appreciate the different abilities of their group members.

### 2. Communication

Communication in English will be improved when learners freely participate in the discussions and presentations. Encourage all learners irrespective of their abilities to participate in the discussions, during presentations by asking questions and during question and answer sessions to either introduce or wrap up the lessons.

All learners should also be encouraged to write summary notes at the end of the lesson as this will help improve their writing skills.

### 3. Critical and creative thinking

In this Unit learners will be doing so many activities that have questions that will make them think critically. It is important to note how they answer the questions to assess if they are able to think critically and answer the questions that will help them comprehend the unit. For instance are they able to note different types of forces? What is the effect of these forces? Do the forces have any use in their dairy life? How can they be able to apply the knowledge about forces that they have learned in physics and in their day-to-day life in general?

## **Links to other subjects**

- Mathematic in calculation: most concepts when working with force and pressure requires that the learners be able to do mathematical calculations. This unit depends a lot on mathematics as a subject. Having a good knowledge on substitution will help them be able to manipulate the equations in this unit so as to get what each question requires them to.
- Biological sciences: there is a great link between this unit and biological sciences. For instance when biologists are dealing with blood pressure, or hypertension they will be required to have the knowledge of pressure to measure them in patients.

## **Cross cutting issues addressed in this unit**

### **1. Environment and sustainability.**

This is through provision of environmental-based activities and discussions as explained in the student's book. For instance, the learners are sensitized to plant more trees and plough across the farm to minimize soil erosion.

### **2. Peace and values education**

- The learners are encouraged not to hurt each other. They also learn to work together in groups and learn to accept each other's contribution even when they differ from their own contribution.
- Make learners aware that people should live in peace and harmony in order to develop. Inform them that they should be willing all the time to accommodate views of others. Make them aware that it is not possible to always agree on everything especially in group discussions so it is important to give and take in areas where disagreements may arise.

### **3. Life Skills**

- As the learners discuss through out the unit they will learn lots of life skills that they can be able to apply it in their real life. They would be able to do their own inventions using the knowledge they acquire from the unit.
- When we use locally available materials to make different tools our work becomes easy and cheap. Encourage learners to develop a habit of being innovative; you can further encourage learners to develop a culture of working together irrespective of gender and to involve all learners in various activities irrespective of their physical status.



### **Attention to special educational needs**

- This unit has a wide range of activities to be done by the learners, Ensure that the learners with disabilities are well taken care of and they are participating in the class activities. This can be done by incorporating the learners with disabilities in the groups and encouraging them to fully participate. Learners often have different capacities and varying needs thus engage the quick learners to help the slow learners in understanding of concepts.
- Plan remedial teaching for slow learners. Gifted learners to be given heavy tasks that require more critical thinking while slow learners are given easy that they can manage though this should not be misconstrued that only easy tasks should be given to them.
- Identify learners with hearing and visual impairment and have them seat in front of the class so that proper attention can be given to them. Large print text should be given to visually impaired learners and hearing aids to those with earring impairment.
- Arrange the classroom such that it will enable the easy movement for the physically challenged learners.

*(Student's book pages 30-73)*

## Learning outcomes

### Knowledge and understanding

- Define and explain the concept of force.
- Identify different types of forces, their nature and their measurements.
- Represent a force as a vector.

### Skills

- Measure force using a spring balance and a force meter.
- Explain natural phenomena depending on force concept and effects of frictional force and pressure.
- Collect and represent results appropriately.
- Interpret results accurately.
- Report findings appropriately.

### Attitudes and values

- Show curiosity in carrying out experiments.
- Appreciate effects of forces in nature.

### Links to other subjects

- Mathematics in calculation: most concepts when working with forces requires that the learners be able to do mathematical calculations for instance when learning combination of forces the algebraic concepts learned in mathematics are important.
- Chemistry in part of reaction.
- Geography (landform formation, ocean currents, solar system etc), Mathematics (vectors addition and scale drawing).

### Cross cutting issues addressed in this unit

#### 1. Environment and sustainability.

This is through provision of environmental-based activities and discussions as explained in the student's book. For instance, activity 2.13 learners are sensitized to plant more trees and plough across the farm to minimize soil erosion.

## 2. Peace and values education

Make learners aware that people should live in peace and harmony in order to develop. Inform them that they should be willing all the time to accommodate views of others. Make them aware that it is not possible to always agree on everything especially in group discussions so it is important to give and take in areas where disagreements may arise.

## 3. Life Skills

When we use locally available materials to make different tools our work becomes easy and cheap. Encourage learners to develop a habit of being innovative, for instance in activity 2.18 they may use copper wire to make a force meter.

You can further encourage learners to develop a culture of working together irrespective of gender and to involve all learners in various activities irrespective of their physical status.

## Contribution to student Competence

- Critical thinking: In this topic learners will be doing so many activities that have questions that will make them think critically. It is important to note how they answer the questions to assess if they are able to think critically and answer the questions that will help them comprehend the Topic. For instance are they able to note different types of forces? What is the effect of these forces? Do the forces have any use in their dairy life? How can they be able to apply the forces they have learned about in physics and in their day-to-day life in general?

## 1. Cooperation

During group discussions and pair works - let learners engage one another by giving a chance for all to participate. Also, you can allow rotational presentations within the group members. Further, encourage learners to be tolerant to other learners views and to understand that people should not necessarily be always right.

**REMEMBER:** You should allow slow learners to do presentations as well and correct them where they go wrong. Further, Advise learners to appreciate the different abilities of their group members.

## 2. Communication

Communication in English will be improved when learners freely participate in the discussions and presentations. Encourage all learners irrespective of their abilities to participate in the discussions, during presentations by asking questions and during question and answer sessions to either introduce or wrap up the lessons.

All learners should also be encouraged to write summary notes at the end of the lesson as this will help improve their writing skills.

### 3. Critical and creative thinking

This competence will be developed by learners as they answer the probing questions as they discuss the results of the various practical activities.

This competence will also come about as learners think about their findings in the activities and as they give out their suggestions on why this is the case.

#### Subtopics

No	Subtopic
2.1	Definition of force.
2.2	Effects of forces
2.3	Measurement of forces
2.4	Representation of forces using vector diagrams.
2.5	Combination of forces
2.6	Types of forces
2.7	Weight and mass

#### Background information and /or prior knowledge

Force is a topic in the branch of physics called mechanics. The understanding of this topic is very crucial as it cuts across many areas in physics. You should engage the learners with practical activities in their daily life with a view to making the learners appreciate and enjoy the effects and application of force in overcoming some common problems in their day to day activities.

#### Attention to special educational needs

- Learners often have different capacities and varying needs thus engage the quick learners to help the slow learners in understanding of concepts.
- Plan remedial teaching for slow learners. Gifted learners to be given heavy tasks that require more critical thinking while slow learners are given easy that they can manage though this should not be misconstrued that only easy tasks should be given to them.
- Identify learners with hearing and visual impairment and have them seat in front of the class so that proper attention can be given to them. Large print text should be given to visually impaired learners and hearing aids to those with earring

impairment.

- Arrange the classroom such that it will enable the easy movement for the physically challenged learners.

## Learning activities

### Specific learning outcome

*By the end of this section, the learner should be able to define force.*

### Teaching guidelines for activity 2.1

- Before the learners do the activity prepare a chart with the pictures shown in fig 2.2 in the learners book. You can also include other pictures that illustrate the push or pulling of objects. Are they able to identify where there is a pull or a push?
- Guide slow learners to identify where there is a push or a pull. Help them to define force. Encourage them to participate in class discussions and give their observations.
- Ask learners to displace a big stone within the school compound using a rope. Caution them to be careful while displacing the stone not to injure themselves.

### Assessment opportunity

#### Observation

Observe the groups as they push the table. Are they able to relate and explain what a force is and where it is applied?

#### Conversation

- Talk to the learners while they are discussing, are they able to explain the force that is making the table move?
- Find out whether the learners know a scientist by the name Isaac Newton. Ask them to use internet to study more about this scientist and report their finding with a view to give the SI unit of force. The SI unit of force is newton (N). The word newton has a small letter n but its symbol is capital N.

### Specific learning outcome

*By the end of this section the learner should be able to list the effects of force.*

### Teaching guidelines for activity 2.2

- Ask the learners to look at the picture in the chart, they can use the pictures in the learners book in place of the chart, explain the effects of a force as illustrated in the pictures?
- Guide them (especially slow learners) through the activities so that they can be able to explain the effects of forces on a body. Encourage them to participate in class discussions and give their observations.
- Give them an opportunity to discuss their observations and present to the class.

### **Teaching guidelines for activity 2.3**

- This activity will be done outside the class thus its prudent to prepare the learners in advance.
- Ask them to try and balance each other on the see saw , are they able to balance ?
- Give them an opportunity to look at the pictures in the book. Can they be able to explain the resultant effect of a force from the pictures?
- You may also give the learners other activities that show turning effect for instance opening a tap and closing of doors. They will learn more about this force in secondary 2.

### **Teaching guidelines for activity 2.4**

- Give the learners an opportunity to get to get two tyres from the school compound. They can also use the soles of their shoes to explain this effect.
- Ensure that the two objects the learners use for comparison , one should be worn out. Are they able to identify this effect of a force?

### **Assessment opportunity**

#### ***Observation***

As the learners do the activity observe and see if they are able to follow through the steps and make observation. Can the learners be able to organise themselves in the groups so that each learner gets an opportunity to swing on the seesaw and explain the effect of force causing them to swing?

#### ***Conversation***

- Talk to the learners while discussing are they able to explain the effects of a force from the two activities ?
- Use the activities in this section and the summary at the end of this section in student's book to summarise the effects of forces. You may assign slow learners different activities to demonstrate effect of forces and allow them to perform them

and report to the class.

### **Specific learning outcome**

*By the end of this section learners should be able to use a force meter to measure force.*

### **Teaching guidelines for activity 2.5**

This activity provides an opportunity for the learners to consider various aspects of scientific instrumentation.

- This important activity deals with fundamentals of the measurement of force. Different indirect means are used to measure many quantities. Here, learners should see that we measure force using the extension of a spring in a force meter. To do so they must first calibrate the spring.
- For the learners to gain familiarity with this new instrument, they should choose an already calibrated meter to measure a range of forces such as force used in opening doors and lifting loads. Students could even make their own force meter from winding a spring using copper wire. They can also use rubber band to make a force meter. It will not have a linear scale but it must not be extended so far so that it exceeds its elastic limit. Give a warning about damaging the force meters due to overloading them.
- Ask them to use a masking tape to cover the scale of the force meter to have a blank strip along the scale.
- Ensure that they hold the force meter vertically without any mass on the hook. Let them mark on the strip to show the zero mark on the force meter.
- Ensure the pointer is next to the mark on the strip to avoid parallax error.
- Now let them start adding 100 g mass to the hook of the force meter one after another each time making a mark on the strip.
- They have now calibrated the force meter. Let them remove the masses and add the unknown mass to the hook. Ask them to use the calibration they had made earlier to note the measurement of the unknown masses. Are they able to take the accurate reading from the force meter?

### **Teaching guidelines for activity 2.6**

- Ask the learners to hook the spring balance horizontally to a rigid support.
- Ensure that each learner pulls the spring horizontally as the partner records the reading on the spring balance. Are they able to note that as they pull the string they are applying their strength thus the reading shows their strength?

## Assessment opportunity

### *Observation*

As the learners do the activity observe and see if they are able to follow through the steps and make observation. In case they are using a modified force meter, are they able to use it correctly?

### *Conversation*

- Talk to the learners while they are doing the activities. Are they able to make the right calibration on the force meter and use it to take the reading?
- Let the learners know that any instrument with a scale must have been calibrated, either by the manufacturer or by the user.
- Discuss with them to understand the calibration scale on the force meter and how to take readings from the force metre. By considering the process of calibration, which they have just carried out, students can assess the uncertainty in any measurement they make with their force meter.

### *Product*

As they do the activities ask them to explain how they get the exact value of the unknown masses. Are they able to explain. Use the learner's answers to evaluate if they have mastered the concepts, and guide them accordingly.

## Specific learning outcome

By the end of this section, the learner should be able to represent forces using vector diagrams.

### Teaching guidelines for activity 2.7

- Let the learners arrange the marbles on top of their desk in a straight line.
- Ask them to give the marbles a straight push towards the others and observe what happens.
- Are they able to note the other marbles start moving immediately they are hit by the other. How can they explain this observation?
- The learners can also stand in a straight line at a reasonable space and act like the marbles. Let the one at the back most push the one in front of him or her. whenever one is pushed he should push the next one. With this they may be able to note the direction in which one moves due to the force pushing him.



- Choose randomly any member from each group to present their findings.
- This section will promote in learners among other competencies oral skills in English in group work discussion. It will also encourage Cooperation and interpersonal relation.

### **Assessment opportunity**

#### ***Observation***

As the learners do the activity observe if they are able to follow the instructions and arrange the marbles in a straight line and hit them.

#### ***Conversation***

- Talk to the learners as they are discussing, are they able to explain how forces can be represented? Can they show the direction in which a force acts?

## **2.5 Combination of Forces**

### **Specific learning out come**

*By the end of this section the learners should be able to combine forces.*

### **Parallel forces**

#### **Teaching guidelines for activity 2.8**

- This activities will be carried outside the class thus its prudent to prepare the learners in advance.
- Ensure that the learners place a block of wood on a rough surface.
- Let them pull the block using the attached spring balance until the block just starts to move. Ensure they record the value of the force applied. Are they able to take the right reading?
- Now let them repeat the steps but now use two identical springs. How do the two values compare? Can they note that the reading on the two instances are equal? Are they able to explain why the two forces are equal?

### **Assessment opportunity**

#### ***Observation***

Observe the groups as the learners do the activity. Ensure that they put the springs parallel to each other.

#### ***Conversation***

- Talk to the learners while discussing are they able to compare the two values and

explain their observation?

- Two springs are used they record the same value that is half the value recorded when one spring is used.
- When two parallel forces act together on a body in the same direction, the resultant force can be added together by ordinary arithmetic.
- Guide them through example 2.1 given in the learners book. Let the learners give their contribution as you solve the activity.

### **Product**

Ask them to do exercise 2.1 given in the learners book. Use it to evaluate how much they have mastered in this section. You may give additional questions from revision materials to enhance the learners understanding.

## **Non parallel forces**

### **Teaching guidelines for activity 2.9**

Ensure that the learners tie the ropes at three different points on the ring as shown in fig 2.16 in the learner's book.

- Ask three of them to pull the rope in different directions. What do they observe? Are they pulling with the same force?
- What happens to the ring when they pull all the three ropes?

### **Addition of non-parallel forces**

#### **Teaching guidelines for activity 2.10**

- For the first part ask learners to cover the top of the table with a plane paper.
- Guide them to hook the spring balances to the wooden blocks and then to loose loops of the spring as shown in fig 2.17 in the learners book.
- Ensure they move the wooden blocks outward until each spring balance shows an appreciable reading. Let them record the readings of the spring balances.
- Tell them to tap the ring and the strings so as to be in their true position. Is the ring balanced? What observation can they make? Are they able to explain why they made this observation?
- Ask them to draw a straight line along each string. Let them mark points A, B, and C along the lines representing the respective strings.
- For part B ask the learners to remove the set up and extrapolate lines through point A, B and C inwards to meet at point O.
- Using suitable scales let them mark off distances OA, OB and OC accurately and

proportional to the readings they recorded for the respective springs.

- Guide them to construct a parallelogram OBRA and the diagonal OR .
- Ask them to find the length OR and compare it with OC. What is the relationship between the forces?

### **Assessment opportunity**

#### ***Observation***

Observe the groups as they do the activity. Are they able to follow through all the steps of the activity.

#### ***Conversation***

- As the learners some questions as they do the activities. Can they explain to explain the observations they are making in every step of the activity?
- Can the learners note that the force OR and OC are equal in magnitude but opposite in direction?
- They should also note that the force OR represents the resultant force exerted by OA and OB. This method of obtaining the resultant of two forces is called the parallelogram law method which says that:

If two forces are represented in magnitude and direction by two sides OA and OB of the parallelogram OARB, then the resultant is represented in magnitude and direction by the diagonal.

Guide them through example 2.2 in the learners book.

#### ***Product***

- Ask them to them to do exercise 2.2 given in the learners book. Use it to evaluate how much the learners have understood. You may create remedial classes for the learners who may be having difficulties. You can also encourage the learners to discuss amongst themselves thus encouraging peer teaching.

### **Specific learning outcome**

*By the end of this section, the learner should be able to name and explain different types of forces. This are contact and non contact forces and give examples of each.*

#### **(a) Tension force**

#### **Teaching guidelines for activity 2.11**

- Guide the learners through the activity as they pull the string. Note that this may

be enjoyable and some learners may forget the aspect they are investigating thus always keep them in check.

- Now ask them to tie a string to a bucket of water and hung it on a rigid support. Ask them to discuss the forces acting on the string.
- Are they able to state the forces acting on the string and the direction it is applied?
- Hold a comprehensive discussion on their findings and allow learners to give supportive argument on there findings.

### **Assessment opportunity**

#### ***Observation***

Observe the learners as they do the activity. Are they able to follow through all the steps of the activity?

#### ***Conversation***

- Ask the learners some questions as they do the activities. Can they be able to explain the observations they are making in every step of the activity? How have they represented the forces acting on the string? Are they able to use scientific terms to explain this forces?

#### ***Product***

As the learners are writing down their observation on the forces acting on the string check their work and guide them accordingly. Check the diagram they have drawn to show the direction in which the forces act. Have they done the correct representation of the forces?

### **(b) Action and reaction force**

#### **Teaching guidelines to activities 2.12 and 2.13**

- Ask the learners to hook one end of the spring balance to a rigid support. Ensure they pull the other end of the string until there is a reading
- Give them an opportunity to discuss what happens to the wall.
- Now let them replace the rigid support with another spring. Ask the them to pull the two springs until the reading in the first spring is the same as before. What is the reading on the second spring?
- Can they be able to explain how the two forces are acting on the string?
- After they have done activity 2.12, Guide them through activity 2.13, that is to demonstrate existence of normal reaction.
- Ask them to press the desk with their thump. What do they feel?
- Ask them to put a wooden block on the bench, and give them an opportunity to

suggest the forces that are acting on the wooden block.

- Let them lift one side of the bench top upwards at some angle, ensuring that the book does not fall.
- Let them identify the forces acting on the wooden block.

### **Assessment opportunity**

#### ***Conversation***

- Ask the learners some questions as they do the activities. Can they be able to explain the observations they are making in every step of the activity?
- Are they able to note that for every action force there is an equal and opposite reaction force?
- Are they able to explain that: When you press on the table the force you feel pressing against your thumb is called the reaction force and the one acted by the thumb on the table is called action force.

The force due to the block is called the normal action force while that due to the table is called normal reaction force.

#### ***Product***

- Ask them to do exercise 2.3 given in the learners book. Use it to evaluate how much the learners have understood. You may create remedial classes for the learners who may be having difficulties.

### **(c) Upthrust**

#### **Teaching guidelines to activity 2.14 and 2.15**

- Provide the learners with solids from the local environment . Ensure that the solids that they use are more dense than water so that they can easily submerge in water. You should also ensure that the solids are not porous or absorbents.
- Ask the learners to suspend a solid in air using a spring balance and note the weight.
- Now let them push the mass upwards gradually with their hands. What happens to the reading on the spring balance?
- Ensure that they fully submerge the solid in water and take the reading. What can they note about the reading of when they submerge the solid in water?
- Let them compare the weight of the solid in air and when it is submerged in water . How do the two weights compare? Are they able to explain why the weight changes and name the force responsible for this observation?

### **Assessment opportunity**

### ***Observation***

Keep going round the class and help all learners to ensure they are all at par.

### ***Conversation***

- As you guide the learners through the discussion let them understand that upthrust is an upward force due to a fluid
- Can they be able to explain that Upthrust depends on :Density of the liquid and the volume of the body immersed in the liquid?
- Guide them through examples and 2.4.
- You may also allow the learners to discuss example 2.5 as you guide them.

### ***Product***

Let the learners do questions 1-5 exercise 2.4 in the learners book in class . Mark their work, do the answers the learners give show that they have mastered the concepts? Give them questions 6-11 as an assignment. This is to ensure that the learners do a self evaluation to master the concepts.

## **(d) Friction force**

### **Specific learning outcome**

By the end of this section, the learner should be able to name and explain what frictional force is , factors affecting friction force and its effects..

### **Teaching guidelines for activity 2.16**

- This activity gives the learners an opportunity for the learners to design an investigation to show the existence of frictional force between surfaces
- Provide the learners with the materials noted in the learners book that they will need for this activity. To enhance creative thinking in learners you can give them an opportunity to get materials from the local environment that they can use to illustrate the existence of friction force between surfaces.
- Ensure that the learners are noting down the correct procedure they are going to follow . How well can they write the procedure?
- Now let them design the experiment and write down their results.
- Check through each group and ensure they are following the procedure they have written . Do they appear to be using a procedure that will illustrate existence of friction force?

### **Teaching guidelines for activity 2.17**

- Ensure that the learners observe the surface of the paper first with their naked eyes,

then through a microscope. Let them note down what they observe. Can they note that as much as the paper may appear to be smooth when observed with naked eyes, it is rough when observed under a microscope?

- Give them an opportunity to discuss their observation. Are they able to note the difference between the two surfacers? How does friction on the two surfaces compare?

### **Teaching guidelines for activity 2.18**

- Ensure that the learners design the correct experiment to show the factors affecting friction force.
- It is wise to give learners an opportunity for them to design other activities that may show existence of friction force. They can use materials like dust or oil to act as lubricants in their experiment. Are they creative enough to design any other experiment?
- Let them use different surfaces with different materials to observe the factors that affect friction.
- Are they able to note this factors? How well can they explain them?

### **Teaching guidelines for activity 2.19**

- Let the learners try to write on a smooth glass, are they able to write? Why is it not easy to write on the smooth surface?
- Using the same pen let them write on a rough surface e.g. a manila paper . Are they able to write? Why is this possible ?
- Give them an opportunity to discuss and write down the effects of friction force.

### **Assessment opportunity**

#### ***Conversation***

- Let the learners understand that friction force is a necessary evil in that it has both advantages and disadvantages and therefore cannot be avoided. Some of the ways that friction helps include:
  - i. Walking or running
  - ii. Breaking of the cars
  - iii. It prevents slipping and sliding e.g. Furniture in our houses
- You can also go through the advantages and disadvantages of friction that the learners have written. Are they able to write the correct notes?
- Summarize this section by formulating some of the questions that are related to this section and elaborate more on some of the ways of reducing friction force that

causes negative impact in our lives.

## **Non contact forces**

### **(a) Electrostatic force**

#### **Teaching guidelines for activity 2.20**

- Note that the activity may be enjoyable and some learners may deviate from the main point of the activity thus it is necessary to ensure that each learner is following the steps.
- Ensure that the learners rub a ruler on a dry cloth and bring the ruler next to pieces of paper. Are they able to note that the pieces of paper are attracted by the ruler? Can they explain why this is observation?
- Give them an opportunity to discuss their observation, are they able to note the type of force that causes their observation?

### **(b) Magnetic force**

#### **Teaching guidelines for activity 2.21**

- Provide the learners with magnets and a magnetic material e.g. an iron rod
- Let the learners suspend one magnet and bring another magnet and an iron rod respectively near the one suspended, each time noting down their observation.
- What happens when the magnets is brought near the suspended one from two different sides? Are the observations the same when an iron rod is used?
- What can they explain causes the magnets to attract each other when brought near the other from one side and rebel on the other end but when an iron rode is used it is attracted from either sides?
- Are the learners able to explain how magnetic force works? Inform the learners that they will learn more about magnetic forces in secondary 2

### **(c) Gravitational force**

#### **Teaching guidelines for activity 2.22**

- Ensure the learners lift up a ball or any other object in the local environment and release it from some height and note to which direction the ball moves. Are the learners able to note the main concept that the objects fall back to the ground?



- Caution the learners not to injure each other as they throw the objects.
- Next ask them to throw the ball up and not how the ball moves.
- Are the learners able to explain why the ball falls when it is released? Why does the ball come back down and rather than keeping on moving higher when its thrown up?
- Can they be able to explain how the ball would move if it was thrown up in a vacuum?

### **Assessment opportunity**

#### ***Observation***

- Observe the learners as they are discussing, are they able to identify gravitational force as the force leading to the observation they make?
- This is a simple activity which requires objects from the local environment thus you should ensure all learners are performing the activity. Do they understand what they are doing and why?

#### ***Product***

- Ask the learners to form groups and do exercise 2.5 in the learners book. Guide them through. Are they able to write the correct answers? Let them debate the answers that they have written in class. Each learner should give supporting information to the answer they give. Are they able to debate constructively?

### **Specific learning outcome**

*By the end of this section, the learner should be able to name the instruments used for measuring weight and mass and distinguish between the two quantities.*

### **Teaching guidelines for activity 2.23**

- Put more emphasize on how weight and mass are measured and the difference between the two quantities. Let the learners know the different instruments used to measure mass and weight and their respective SI units.
- Ask them to study the spring balances provided to them. Are they able to explain how the scale is used?
- As they tie a small stone to the spring balance ensure that they are taking the right reading from the scale.

- Allow them to discuss as a class their findings as you guide them through are they able to discuss constructively?.

### **Teaching guidelines for activity 2.23**

- Ask the learners to form groups and in their groups deduce the relationship between mass and weight . Are they able to state the difference between the two quantities?
- Ensure that they discuss and learn how to get the other given one of the two.
- Let them compare their notes with other groups, are they able to note the difference?

### **Assessment opportunity**

#### ***Product***

- Ask them to do Exercise 2.6 in student's book .Give the learners an opportunity to discuss the exercise in class as you guide them. Are those who were having difficulties in answering the questions following?

#### ***Topic summary***

At random ask different learners to lead others in a brief discussion of different concepts highlighted in the topic summary given in the students book, by asking them probing questions. Help them recall the concepts.

Organize the learners into groups and let them identify vocabulary, key words and concepts that are main areas of achieving the learning objectives.

#### ***Topic assessment.***

This topic assessment combines many aspects that are related to forces. We have deliberately given many questions to cover the topic successfully use different methods of teaching and evaluation to ensure learners benefit from topic.

### **Answers to numerical questions**

#### **Exercise 2.1**

3 (a) 0 N (b) 30 N (c) 13 N

#### **Exercise 2.2**

3 (b) 210 N

#### **Exercise 2.4**

2. 0.45 N 5. 7.9842 N 6. 102 N 8. 5.45584 N

- 9 (a) 14 960 kg/m<sup>2</sup> (b) 17.7 N  
 10. (a) 3.95 N (b) 7.105 N (c) 7.105 × 10<sup>-4</sup> M<sup>3</sup>  
 11. (a) 0.117 kg (b) 0.243 N (c) 0.47475 N

**Exercise 2.6**

3. (a) 3 N (b) 7 000 N (c) 5 × 10<sup>-7</sup> N  
 4. 0.2 N 5 (a) 1.6 m/s<sup>2</sup> (b) 24 N  
 6.

Mass	Weight (N)
220	2.2
14g	0.14
4 560	45.6
162	1.62
36 600	366
56 700	567

**Topic test 2**

4. 250 kg  
 6. (a) 3N (b) 9 000 N (c) 6 × 10<sup>-6</sup> N  
 7. 0.3 N  
 10. (a) 50 N due west (b) 200 N due North  
 12. (a) 66.7 N (b) 400 N  
 13. 11.5 N  
 14. (a) 100 N (b) 93 N (c) 70.7 N (d) 93 N (e) 0 N  
 15. 2.07 N 16. 690 N 17. 165.4 N  
 18. (a) 917 800 N (b) 915 870 N  
 19. 91.7 cm

*(Student's book pages 74-104)*

**Background information and / or Prior knowledge**

- Pressure is a topic in a branch of physics called mechanics. The understanding of this topic is very crucial since it applies in many areas of life e.g. hospitals, industries and many other areas. It will be very important for the learners to well understand the concepts in this topic as it will help them appreciate its application in different fields.
- In topic 2 the learners learnt about force. There is a great relationship between force and pressure. For instance, if you talk about the force applied over a given area that translates to pressure. Build on this relationship to introduce the topic on pressure. You should engage the learners with practical activities in their daily life with a view of making them appreciate and enjoy as they learn the different aspects in this topic, which will lead to good understanding of the topic.

**Subtopics**

No.	Subtopics
3.1	Force acting on a surface
3.2	Definition of a unit pressure
3.3	Pressure in solids
3.4	Pressure in liquids
3.5	Pressure in gases
3.6	Transmission of pressure in fluids
3.7	Application of Pascal's principle
3.8	Atmospheric pressure

**Suggested teaching/learning activities**

**3.1 Force acting on a surface**

**Specific learning outcome**

*By the end of this section, the learner should be able to calculate, force acting on a particular area.*

### Teaching guidelines for activity 3.1

- Because the activity will dwell much on the weight of the learners it is advisable to tell the learners to measure their weight prior to the activity. This will help save time they spend in the activity.
- Provide the learners with rectangular piece of wood and a meter rule. The sides of the rectangular pieces should be significantly different in size so as to help learners note the difference in pressure when each side is used.
- As they step on the piece of wood, are they able to note the relationship between their weight and the pressure exerted by the piece of wood? Are they able to note that pressure exerted from different sides differs because of the difference in surface area?

### Assessment opportunities

#### Observation

- Observe as the learners are doing the activity? Are they able to note why the different sides result to different pressure? How well can they apply the information they learned in the topic of force on the relationship between mass and weight?

## 3.2 Definition of unit of pressure

### Specific learning outcome

*By the end of this section, the learner should be able to define and state the SI units of pressure correctly.*

### Teaching guidelines for activity 3.2

- In case there is no piece of soap the learners can mold clay or plastacine to take the shape of a piece of soap to use in the experiment. They can also use objects that are sharp on one side and blunt on the other end.
- Let them use the sharp object to pierce the soap from the sharp end followed by the blunt end. From what end do they use less pressure to make the object pierce into the soap? Can they be able to relate this observation so as to arrive at the relationship between force, pressure and area?

### Assessment opportunities

#### Conversation

- Give an opportunity to each group to explain their observation to the class. Are they able to give the correct explanation how pressure relates to force and area? Can they

be able to use their results to get the formula relating to force, pressure and area?

- Are they able to define pressure as the force acting normally (perpendicular) on a unit area and its SI unit is pascal (Pa)?
- Note the errors the learners make in their discussion and correct them. Use this chance to assess whether the objectives have been made as you conclude this part.

### 3.3 Pressure in solids

#### Specific learning outcome

*By the end of this section, the learner should be able to explain pressure in solids and solve problems that involve pressure in solids.*

#### Teaching guidelines for activity 3.3

- Ask the learners to take a rectangular shaped stone and place it on wet clay soil on the three different surfaces of the stone. What observation do they make? How deep does the stone penetrate into the soil in each case? How does the pressure acting on the different surfaces compare?
- What will happen if the stone was sharpened on one of the sides? Can the learners use the observation they have made to explain why it is not advisable to walk with sharp shoes on wet ground?

#### Assessment opportunities

##### *Conversation*

- Can they be able to tell when the highest pressure is exerted?
- Examples 3.1 to 3.4 will give you the perfect opportunity to evaluate and see if the learners have understood the concepts. It will be prudent if you copy the examples on the board and select learners at random to lead the others in solving it on the board. This will help the learners develop good oral skills as they guide the others on the board. This will also help you as a teacher to assess how much the learners have understood as well as where to put more emphasis to help the learners. From the arguments they are making when discussing the examples, are the learners able to use scientific terms to make their argument?

##### *Product*

Ask the learners to do exercise 3.1 given in the student's book. Mark their work and guide them accordingly. Are their answer depicting mastery of the concepts that they have already covered? Use this to gauge how much the learners have understood the

concepts in this section. You may create remedial classes to help those who may be having difficulties.

### 3.4 Pressure in liquid

#### Specific learning outcome

*By the end of this section, the learner should be able to explain pressure in liquids.*

#### Teaching guidelines for activity 3.4

- This activity helps the learner to get a good understanding of the pressure in liquids.
- As the learners pierce the holes through the containers, ensure that the holes are of a reasonable size that will lead to learners making correct observations.

Can the learners feel the pressure of the water through the hole? Would they feel the same pressure if the hole was reduced in size? Why? What happens when they remove the finger? Can they be able to explain how pressure forces the water out of the hole?

#### Teaching guidelines for activity 3.5

- This is an activity that gives the learners an opportunity to design their own investigation and use it to make relevant conclusion.
- Let them use locally available materials to investigate the direction in which liquid pressure acts.
- Are they able to come up with relevant investigation design? How well can they explain their investigation?

#### Assessment opportunity

##### *Product*

Check the design of every group; have they made a relevant design? Can the design they have made be used to show that liquid pressure acts in all directions? Have they grasped this concept about liquids?

#### Teaching guidelines for activity 3.6

- The polythene bag used should be pierced at different places. As the learners put water in the polythene bag are they able to note that water oozes out from all the holes? How can they explain this concept of pressure at equal length act equally in all directions?
- Having done activities 3.5, some learners might have noticed that at equal depths is same in all directions. But it is important for the learners to repeat this activity just to emphasize this concept.

- Give the learners an opportunity to hold a class discussion on the concepts they have investigated.

### **Assessment opportunities**

#### ***Conversation***

Through question-answer method, assess the learners whether they have understood each activity. Are they able to explain the concept of pressure at equal length acting equally in all directions? Help those who may be unable to answer correctly.

#### **Teaching guidelines for activity 3.7 and 3.8**

- Ask the learners to make holes in a container along one edge. The holes should be made along one line to help them make a good observation.
- They should keep pouring the water to the container to keep the water at the same level as they make the observation. Can they be able to explain why is it necessary to keep the water at the same level as they make the observation?
- How can they compare the horizontal distance travelled by the water from the three holes? What causes this difference?
- Can they use their conclusion to explain why dams are usually built to be thicker with depth?
- Now let them use different liquids in place of water, and observe the length through which each liquids travel from each hole. Are they able to make a comparison between the different liquids? What makes different liquids flow out to different lengths?

### **Assessment opportunities**

#### ***Conversation***

Evaluate the reasons the learners are giving for their observations, are they able to explain scientifically what is causing the difference in the horizontal distance? Why do different liquids result in different horizontal distance even though the size of the holes is the same? Can they relate this concept to what they have already learned on viscosity?

#### ***Product***

Let the learners use the reasons they have given in activity 3.7 and 3.8 to deduce what factors affect pressure in liquids. Can they be able to explain them?



### 3.5 Pressure in gases

#### Specific learning outcome

*By the end of this section, the learner should be able to explain pressure in gases.*

#### Teaching guidelines for activity 3.9

- Ask the learners to blow air into the balloon. Are they able to explain why the balloon increases in size as they blow air into the balloon? Can they be able to set up another illustration to demonstrate pressure in gases?
- In what direction is air pressure exerted on the ballon?

#### Assessment opportunities

##### *Product*

As the learners write down the notes to demonstrate how air pressure acts on the container, are they able to explain this concept scientifically?

### 3.6 Transmission of pressure in fluids

#### Specific learning outcome

*By the end of this section, the learners should be able to state, explain, and solve problems on Pascal's principle*

#### Teaching guidelines for activity 3.10

- The two syringes used in this activity should be having different cross sectional area. Let the learners connect the two syringes to the plastic tube a shown in the learner's book with mass  $m_1$  on piston A and mass  $m_2$  on piston B. What happens to the pistons? What causes the change in one side of the system as they do the activity?
- Guide them through the steps in the activity and let a member from each group lead others in the discussion of their observation
- It is important you take enough time to guide your learners adequately and satisfactory. Emphasize on the word enclosed/confined when stating Pascal's principle.
- Ask the secretaries from each group to give a summarized report of their discussion
- This activity creates interpersonal relation as learners work together towards a common goal.

- It also enhances critical thinking as learners/ critically analyze observations in the activity to give a report

### **Assessment opportunity**

#### ***Conversation***

Copy example 3.6 and 3.7 on the board and ask the learners to close their textbooks. Let the learners contribute as you solve the example. Are they able to state the relationship in the formula used to solve the example? As you guide them through the examples keep asking the learners probing questions as this makes them think critically to help master the concepts.

#### ***Product***

Ask the learners to do Exercise 3.3 thereafter as a class assignment. Are they able to solve the questions with ease? Use this exercise to evaluate if the learners have mastered the concepts in this section. The learners can form study groups after they have done the exercise, help them form the groups to discuss their answers. This helps the slow learners to learn from those who have already understood the concepts.

## **3.7 Application of Pascal principle**

### **Specific learning outcome**

*By the end of this section, the learner should be able to describe the application of Pascal's principle in hydraulic brakes, hydraulic press, hydraulic jack, hydraulic lift pump and other applications of Pascal principle.*

### **Teaching guidelines for activity 3.11**

- Give the learners a well-drawn chart of a hydraulic system. Let the group leader lead others in doing the activities and the secretary to write down harmonized point from their discussion. Are they able use the hydraulic system to explain how pressure is transmitted in fluids?
- Can they give and explain other applications of transmission in fluids?
- Ask the learners to choose someone to give a summarize report on how the hydraulic brakes works.
- This activity will promote in learners among other competencies:
  1. Critical thinking as learners explain critically how hydraulic brakes function.
  2. Communication skills in English as learners discuss in groups or explain to the whole class the hydraulic brake function

## Assessment opportunity

### **Observation**

This part is a fundamental part of the topic and requires adequate time. Use different ways including use of charts to help the learners understand it better. It will make no value if learners can state Pascal's principle correctly but be unable to explain its applications. Thus observe as the learners do the discussions have they have understood the applications of Pascal's principle?

### **Conversation**

To ensure that all learners in that particular group have understood, choose randomly anyone of them to explain to the class. Listen to them as they explain. Are they able to use scientific terms in their explanation? It is worth ensuring that all learners are engaged in activity to ensure that objective is achieved.

### **Product**

Check the notes the learners have written on the different applications of transmission of pressure in fluids. Are they able to give a variety of applications? How well have they explained the applications? Guide them on the different applications that they have mentioned and how they work.

## 3.9 Atmospheric pressure

### **Specific learning outcome**

*By the end of this section the learner should be able to explain the existence of force exerted by air on a surface.*

### **Teaching guidelines for activity 3.12**

- Learners already have an idea on what atmospheric pressure is and how to demonstrate its existence. Using question and answer method, introduce the lesson letting the learners know the importance of this section of the topic as they will be learning the existence of atmospheric pressure and how to demonstrate it.
- Ensure as the learners are inverting the tumblers, they do it in a way that the water does not spill over.
- As they remove the cardboard, ensure that they are not near their books to avoid making their books wet. What observation do they make?

- How does the atmospheric pressure act on the cardboard?
- The learners can put hot water in a plastic bottle and cork it. They should then cool it and observe what happens to the bottle. Are they able to explain what happens to the bottle? Why does the bottle crush? How does the atmospheric pressure act on the bottle?

### **Assessment opportunity**

#### ***Observation***

Go around and listen to the way the students responds to the questions. Correct any wrong response and guide them appropriately to understand the objective of the activity i.e. to illustrate the existence of the atmospheric pressure. By doing so, you will ensure all learners are participating by give their views hence promoting communication skills in them.

#### ***Conversation***

Are the learners able to explain that the atmospheric pressure acting on the cardboard from outside is greater than the pressure due to the weight of water acting on the cardboard from inside? Hence the water in the glass tumbler does not flow when it is inverted

### **Teaching guidelines for activity 3.13**

- With your guidance, lead them through the steps of doing a comprehensive research on factors that affects the atmospheric pressure i.e. altitude, temperature, water vapor concentration and wind pattern from internet and reference books.
- Note that some students may open different sites such as Facebook, twitter and sports thus deviating from the main object of the research. It is therefore important to go around the class and check whether they are doing the right thing. It will be of great importance that you restrict the use of this sites in the devices the learners are using. Knowing how to do constructive research is important to learners since it will be promoting their **research and problem solving skills** that will be useful in their life time (**lifelong learning**).
- Give them few minutes to discuss their findings and let the group secretaries write down the main points from the discussion. This will promote **communication** and **leadership skills**.
- Hold a whole class discussion and ask the group secretaries to give the summarise report to the class. Use the opportunity to point out omissions and correct any error in each report presented.
- Are they able to state and explain all the factors that influence atmospheric pressure? How detailed is their explanation?

## **Assessment opportunity**

### ***Conversation***

Go around and listen how the student responds to the questions.

- The factors that affect the atmospheric pressure include,
  - i. Altitude
  - ii. Temperature
  - iii. Water Vapor concentration
  - iv. Wind pattern

Are the learners able to explain how each of the factors affects the atmospheric pressure?

How well can they explain why weather forecast always focus on areas of low and high altitude?

### ***Product***

Ask learners to attempt all questions in the exercise 3.5 in the learner's book. Are they able to give the correct answers? Ensure that you have marked their work and guide them appropriately where they may have challenges. You may encourage them to form discussion groups to discuss the questions as revision criteria. This helps encourage the learners to have peer education.

## **Measurement of atmospheric pressure**

### **Teaching guidelines for activity 3.14**

- Before they start doing activity 3.14, bring to attention of learners that mercury barometer is fragile and costly, mercury is also explosive and a pollutant. They should therefore handle it with a great care.
- Guide the learners through the activity. Identify raised points and lower ones within the school compound and let them move with the mercury barometer to those points as they note any changes in the level of mercury in the barometer. Are they able to note the changes? How can they explain what lead to the changes?
- Ask them to return back to class. Give them an opportunity to discuss with in groups other types of barometers that can be used to measure atmospheric pressure. How well can they explain how the barometers they have stated works?

## **Assessment opportunity**

### ***Observation***

- Observe as the learners are doing the discussion, is each learner making a contribution in the discussion? Let the learners choose one of them to present their findings to the class. Is the learner able to present the points they have discussed? Time may be insufficient, so let each group give a brief summary.

### *Conversation*

- Are the learners able to explain that the mercury barometer uses the mercury level to depending on the height above sea level? Are they able to state and explain how atmospheric pressure is measured using the different types of barometers?

### *Product*

Ask learners to do all questions in exercise 3.5 in the learner's book. Are they able to answer the questions constructively? How well are their answers explained? Mark their work and use this to gauge how much the learners have understood in the lesson. How well are they able to respond to the questions? Are they able to answer all the questions with scientific language?

### **Application of atmospheric pressure**

#### **Teaching guidelines for activity 3.15**

- Go around checking whether the learners are doing the right thing. Help those who may have difficulty in any step of the activity. The learners with sight challenges can be given the straw by the other learners and then helped to dip it in clean water before asked to suck. Note that you should provide learners with clean drinking water because some may drink the water as they suck.
- With your guidance, allow them to discuss their findings for few minutes before asking the secretaries from each group to give a report to the whole class on their findings. This will promote leadership and communication skills in learners. Are they able to explain how atmospheric pressure acts?
- Give them time to discuss other applications of atmospheric pressure.
- Hold a class discussion on their findings and correct any errors (if any) in each report given. At this point, help learners to realize the importance of accepting other people's opinion whether they are right or wrong and in case they disagree, let them do so constructively. This will promote peace and harmony among the learners.

### **Assessment opportunity**

#### *Conversation*

- Having discussed learner finding from the activities, can they be able to explain how drinking straw, syringe, lift pump, siphon, automatic flashing unit rubber sucker and vacuum cleaner operates? How well can they atmospheric pressure acts on each of the instrument?
- At this juncture, draw the attention of learners into the importance of **keeping the environment we live in clean** all the time, that is to minimize the diseases associated with a dirty environment.

### **Product**

Ask learners to attempt all question provided in exercise 3.6 in the student's book. Mark learner's work and guide them appropriately. Are they able to think critically and answer the questions given?

### **Topic assessment**

- Ask the learners to do the topic test 3 given at the end of the topic
- Mark their work and assess the extent to which they have mastered the concepts learnt in the unit.
- Organise remedial teaching for those who may still be having challenges.

### **Answers to numerical questions**

#### **Exercise 3.1**

5. 800 000 N/m<sup>2</sup>    6. (b) 9 000 000 N/m<sup>2</sup>    8. 5 000 N/m<sup>2</sup>

#### **Exercise 3.2**

3. (b) 103 360 pa

#### **Exercise 3.3**

4. 0.5 N    6. 35 000 N  
7. (i) 12.2 N/cm<sup>2</sup>    (ii) 12.2 N/cm<sup>2</sup>    (iii) 5 988.7 N

#### **Exercise 3.5**

5. 100 640 N/m<sup>2</sup>    6. 10 146 m

#### **Topic text 3**

1. (a) 0.032 N    (b) 80N/m<sup>2</sup>  
2. (b)  $P_{\max} = 6\,000\text{ N/m}^2$   
 $P_{\min} = 750\text{ N/m}^2$   
 $\text{Area}_{\min} = 6.0 \times 10^{-4}\text{ m}^2$   
 $\text{Area}_{\max} = 0.0048\text{ m}^2$   
3. 200 000 N/m<sup>2</sup>    4. 2.5 kg  
5. (a) 0.04 m<sup>2</sup>    (b) 0.2 m or 20 cm  
7. 800 kg/m<sup>3</sup>    9.  $10.506 \times 10^6\text{ N/m}^2$   
10. 1 000 kg/m<sup>3</sup>    11. 1 500 N/m<sup>2</sup>  
14. 3 590.4 m

**Topics in the unit**

Topic 4: Effects of temperature change on matter

<b>Learn about</b>		<b>Key inquiry questions</b>
<p>Learners should investigate in groups the effects of temperature changes on matter using a range of types of thermometers and temperature scales which include Celsius and Fahrenheit and understand Kelvin (absolute temperature). Investigations should include temperature change on water in its three states and they should understand the difference between heat and temperature. Learners should explain their findings in terms of the particle theory and apply this to a range of matter.</p>		<p>How do different types of thermometers function?</p> <p>How the dimensions of objects change as a result of temperature?</p> <p>What determines whether a substance is a gas, a liquid or solid?</p> <p>How does the temperature affect objects?</p> <p>Why are fixed points necessary in order to establish a thermometer scale?</p>
<b>Learning Outcomes</b>		
<b>Knowledge and Understanding</b>	<b>Skills</b>	<b>Attitudes</b>
<p>Understand the effects of temperature changes on matter.</p>	<p>Observing carefully</p> <p>Predict what might happen</p> <p>Use appropriate measures</p> <p>Collect and present results appropriate in writing or drawing</p> <p>Interpret results accurately</p> <p>Report findings appropriately</p> <p>Interpret results accurately</p> <p>Report findings appropriately</p>	<p>Show curiosity in carrying experiments.</p>



## **Contribution to student competencies**

- Critical and creative thinking: this is one of the units that give the learners an opportunity to make interpretation of results and make a scientific conclusion. For the learners to conclude on the different effects of temperature on matter they will need to think critically to interpret the results before they conclude.
- Oral skills: As the learners will be making the presentation of their findings to the class they will be developing their oral skills. You should encourage them to make contributions in the groups as this also helps them increase their self-esteem.

## **Links to other Subjects**

- Geography weather climate- in geography they learners cover a lot about the change in climate due to global warming. They should understand that global warming is due to temperature change. This understanding and the interlinking of geography to this topic will help the learners appreciate the impact of this topic in their day-to-day life.
- Biology: each living organism has specific temperature for existents.

## **Cross cutting issues addressed in this unit**

### **Environment and sustainability:**

In this topic learners will be learning about temperature and effects of temperature change. This gives he learners a perfect opportunity to learn about environment and sustainability through appreciating the effects of change in temperature on climate.

### **Life skills:**

As the learners discuss through out the topic they will learn lots of life skills. For instance as the learners learn about boiling point and evaporation and factors affecting boiling point, they can be able to apply it in their real life. They would be able to do their own inventions using the knowledge they acquire from the unit.

### **Peace and values**

- The learners are encouraged not to hurt each other. They also learn to work together in groups and learn to accept each other's contribution even when they differ from their own contribution.

### **Attention to special needs**

- Ensure that the learners with disabilities are well taken care of and they are participating in the class activities. Encourage other students to form groups with them reminding them that disability is not inability.
- Those with visual impairment should seat in front of the class where they can be able to see the black board with ease.

## Topic 4

# Effects of temperature change on matter

*(Student's book pages 106-144)*

### Background information and /or prior knowledge

Through the school of pain the learners have learned that they should not touch hot objects. What they may not be able to explain is how this happens and the effects of the change in temperature. Create the eagerness of the learners to learn this topic by making them aware of their experiences on change in temperature. Now that the students have covered kinetic theory

In topic 1 the learners covered information on kinetic theory. The learners were also introduced to energy in Primary. Build on this fact to explain heat as a form of energy as you introduce kinetic energy of matter. Ask them probing questions on kinetic theory, difference between heat and temperature and any other aspects that they learned that entails heat and temperature. The questions will help them recall what they have already learned and this will help them understand the concepts in this topic.

### Subtopics

No.	Subtopics
4.1	Heat as a form of energy
4.2	Temperature scales
4.3	Thermal equilibrium
4.4	Measurement of temperature.
4.5	Types of thermometers
4.6	Calibration of thermometers
4.7	Effects of temperature change to solids
4.8	Effect of change in temperature on liquids
4.9	Evaporation
4.10	Sublimation and deposition
4.11	Applications of effects of heat on a substance
4.12	The refrigerator

## Suggested teaching/learning activities

### 4.1 Heat as a form of energy

#### Specific learning outcome

*By the end of this section the learner should be able to describe heat as a form of energy.*

#### Teaching guidelines for activity 4.1

- Let the learners put some ice in a bowl, and then feel the bowl with the palm of their hands. What can they feel?
- Caution the learners to be careful as they pour the hot water into the bowl so that the water does not spill on them or others.
- Now let them pour hot water into the bowl containing ice wait for some few minutes and feel it with the palm of their hands. What can they feel? How can they explain this observation? Are they able to relate what they are feeling to the form of heat?
- Give opportunity to each group to explain their observation to the class. Are they able to give the correct explanation?
- This activity will promote among other competence; communication skills in English and co-operation and interpersonal relation among learners.

#### Assessment opportunities

##### *Conversation*

Let the learners explain why they are able to feel the heat with the palm of their hand. Are they able to define what heat is? How can they explain their observation? Are they able to give their explanation scientifically?

##### *Product*

Let the learners read their findings loudly to the class. Have the learners made the correct observations? Note the errors the learners make in their discussion and correct them. Use this chance to assess whether the objectives have been made as you conclude this section.

### 4.2 Temperature scales

#### Specific learning outcome

*By the end of this topic the learner should be able to convert the magnitude of temperature from one scale to the other.*

### **Teaching guidelines for activity 4.2**

- Ask the learners to access to the internet or resource persons and do research on:
  - i. The different types of temperature scales
  - ii. How the scales of thermometers are graduated
  - iii. Maximum and minimum temperature values on the scale and how this values are called
- Guide them especially the slow learners on how to do research from the Internet and reference book i.e. searching for specific relevant areas only.
- Let each group present their findings through one of their members chosen at random. Are they able to make a good summary on temperature scales and present the same to the class in their discussion?

### **Assessment opportunities**

#### ***Observation***

Observe as the learners as they do the research, how well have they mastered the research technique? Can they be able to make a research on the temperature scales and note them down?

### **Conversion of temperature from one scale to another**

#### **Teaching guidelines for activity 4.3**

- In activity 4.2 the learners did a research on the different temperature scales, can they remember each scale that they did a research on?
- Ensure that the learners have access to the Internet or reference books. Ask them to do a research on how to convert one temperature scale to another.
- What is the difference between the temperature scales? Are they able to convert the temperature scale from on to another?

### **Assessment opportunities**

#### **Conversation**

- Summarise the discussion by guiding learners through Examples 4.1 to 4.3 given in student's book to show them how to convert given magnitude of temperature from one scale to other.
- Select learners at random to guide the class in doing example 4.4- 4.9 on the chalkboard. How well can they be able to do the examples?

## **Product**

Ask the learners to do exercise 4.1 provided in the learner's book. Are they able to solve the questions? Mark their work. Guide them through the questions if they may be having any difficulty. You may give them more work as an assignment from other sources to enhance their understanding.

## **4.3 Thermal equilibrium**

### **Specific learning outcome**

*By the end of this section, the learner should be able to explain the meaning of thermal equilibrium.*

### **Teaching guidelines for activity 4.4**

- Ask the learners to follow the procedure given in the learner's book. Let them pour water into a beaker and place it on a source of heat for 30 min then measure the temperature  $T_1$  and record.
- Ask them to put cold water in another beaker and measure its temperature  $T_2$ . Ensure they use the same amount of water this will help at arriving at the equilibrium with ease. The water should also be less than half in each beaker to avoid an over flow when they pour it into one beaker.
- Ensure they mix the warm water and the cold water then measure the temperature  $T_3$ . How can they describe the temperature  $T_3$ . Are they able to note that that is the equilibrium temperature?
- To help in better understanding of thermal equilibrium let them do a research on thermal equilibrium and present their findings to the whole class. Does the research help enhance their understanding of thermal equilibrium?
- Ask the learners explain how thermal equilibrium is important to the survival of living things. Are they able to explain this concept scientifically?

### **Assessment opportunities**

#### **Observation**

Observe as the learners do this activity, are they holding the thermometers correctly so has not to interfere with the reading? The common mistake that the learners make is to hold the thermometer at the bulb thus the thermometer takes the temperature of their hands leading to an error in the actual reading. Are they able to record the right temperatures?

### ***Conversation***

As the learners are making their observations and taking temperature reading you can ask them probing questions to ensure that they remember how convert the temperature into different scale.

### ***Product***

Let the learners do a research from the Internet on the meaning of thermal equilibrium and make notes in their books. Check their work and guide them accordingly.

You may give them an assignment for them to convert the temperatures they recorded into different scales for them to appreciate what they had learned earlier.

## **4.4 Measurement of temperature**

### **Specific learning outcome**

*By the end of this section the learners should be able to explain how temperature is measured. They should also be able to measure temperature using different thermometers available.*

### **Teaching guidelines for activity 4.5**

- Ask them to choose the group leader and secretary and ensure that learners who have been group leaders and secretaries are not chosen again. By doing so all learners will feel part of the group and thus promoting teamwork and leadership skills to all learners.
- Allow each group to do research from the Internet on the different types of thermometric substances. Name some of thermometric substances used in thermometers? Why and when is each of the substance that they have discussed preferred?
- What are the advantages of using each one of the substances they have identified?
- Let them present their findings in a class discussion, this will help them develop their oral skills and help in mastery of language.
- After each group has presented let the learners do comparison of the notes from each group.

### **Assessment opportunities**

### ***Conversation***

Observe as the learners as they do the activity. Are they able to do constructive research? Are the learners able to make notes from their research? Guide them on how to note down the summary of their research. Help them to go to the correct sites.

## 4.5 Types of thermometers

### Specific learning outcome

*By the end of this section, the learner should be able to classify different types of thermometers according to their use or the substance used to make them.*

### Teaching guidelines for activity 4.6

- Let the learners conduct research from the Internet, reference materials and resource persons on the different thermometers available for use. Have they ever used any of the thermometers they have discussed?
- How are the thermometers calibrated? Can they be able to explain how the thermometers they have discussed are used?

### Teaching guidelines for activity 4.7

- Borrow any of the thermometer(s) that you may be lacking. Before the activity.
- In case the thermometers are not available in the school you can draw the various thermometers on a manila paper to aid the learners in discussing them. You can also give the learners pictures of the thermometers that are not available to aid them in visual recognition of the thermometer.
- Give the learner an opportunity to carry out the activity following the procedure given in the learner's book.
- Ensure that when they are using the alcohol in glass thermometer the temperature of the water they are measuring should not exceed  $78^{\circ}$ . Are they able to note that  $78^{\circ}$  is the boiling point of alcohol?
- Are they able to discuss how the thermometer is used?
- Care must be taken when using mercury-in-glass thermometer. In case of breakage, use sculpture to collect the droplets of mercury that may have splashed over. Mercury causes cancer!
- The learners should know the different types of thermometers this includes: liquid in glass thermometer, electrical thermometer, digital thermometer and gas thermometer.

### Assessment opportunities

#### ***Product***

Are the learners able to make notes from their research? Guide them on how to note down the summary of their research.

## Liquid in glass thermometer

### Clinical thermometer

#### Teaching guidelines teaching guidelines for activity 4.8

- Since the learners have not done thermal expansion of matter, it is prudent that you explain to them through simple activities i.e. ball and ring experiment, holding a round bottomed flask containing color liquid and fitted with a rubber band and capillary tube with your palms. This is necessary because the learners need to understand what makes the liquid to move up the capillary.
- Allow the learners in groups to perform activities 4.8 given in student's book that's to observe the working of a clinical thermometer. Can they explain how it works? When is it used? Does the thermometer have any notable difference from others? What is the scale of the clinical thermometer? What informed the creating of the scale of a clinical thermometer and what thermometric liquid is used?
- Ask the learners to note down the range of scale; minimum and maximum values of the scale and also the features of the thermometer.
- Ensure that they place it correctly in their armpits for a couple of minutes.
- Let them note the reading where the reading becomes steady. Let them compare the results amongst them. What observation do they make?
- Are they able to explain and discuss the usefulness of the constriction in the thermometer?
- Allow other members in the same group to repeat the experiment. This will ensure full participation by all learners.

### Six's maximum and minimum thermometer

#### Teaching guidelines teaching guidelines for activity 4.9

- Ask the learners to do a research 'from the Internet and reference materials or resource persons.
- From the research let them note how the thermometer is calibrated, the range of its scale, liquids used and how it works.
- Allow them to present their findings in a class discussion. Are they able to make the correct Notes on the thermometer?
- Each learner to Summarize the key points and write notes in their books.



## Assessment opportunities

### **Conversation**

Ask them questions as they do the activities to see if they are following. They don't have to be right, as you will clarify for them the points as you discuss with them.

### **Product**

As the learners discuss ask them to note down the differences they can see about the different thermometers. Have they noted down all the important points? Guide them to master the facts.

## 4.6 Calibration of thermometers

### Specific learning outcome

*By the end of this section the learner should be able to calibrate a thermometer.*

### Teaching guideline for activity 4.10

- Ensure that the learners immerse the tube in the beaker containing ice. What observation do they make? How well do they explain why it is necessary to completely immerse the bulb? Can they be able to identify the lower point as the lower fixed point of a thermometer?
- Now ask them to expose the bulb to the steam just above the boiling point of water. Let them mark the highest point when there is no change in the level of the mercury. What name is given to this point?
- Is the range they have got same for every liquid? Let them explain their answer.

## Assessment opportunities

### **Observation**

Observe as the learners as they do the activity. Are they able to make the calibration? Guide the learners as they do the calibration and guide them through.

### **Conversation**

- Ask the learners to do example 4.10 in their books, check as they are doing example 4.10 can they be able to use this example to further understand the concept of calibrating the thermometer?

### ***Product***

- Ask the learners to do exercise 4.2 in the learner's book. Mark their work, from the answers they give in the exercise, how well have they understood the concepts? Are they able to use scientific terms to express their answers?
- You should use this exercise to gauge how much the learners have understood so as to know if you can organize remedial classes to teach further.

## **4.7 Effects of temperature change on solids**

### **Specific learning outcome**

*By the end of this section, the learner should be able to explain the effect of temperature change on solids.*

### **Teaching guidelines for activity 4.11**

- Ensure that the learners wear safety glasses or goggles through out the activity.
- Let them use an immersion heater as it gives a constant quantity of heat that does not fluctuate with time.
- As the learners are taking the temperature at intervals are they taking the right reading? Can they be able to note the pattern, which the reading takes so as to aid them in taking the right reading?
- Provide the learners with a graph paper to draw the graph of temperature ( $^{\circ}\text{C}$ ) against time. Are the learners able to choose a suitable scale for the graph?
- What interpretation can they make from the graph? Can they be able to explain what is happening at every step of the graph? Are they able to identify the melting point of ice from the graph? What value do they get?

### **Assessment opportunities**

#### ***Observation***

Observe as the learners as they are drawing the graph, what scale have they chosen, Does the data they have collected help in the drawing of the graph and does it make any significant meaning?

#### ***Conversation***

Ask them questions as they do the activities to see if they are able to note the effects of temperature on solids. They don't have to be right, as you will clarify for them the points as you discuss with them.

### **Product**

- Look at the data the learners have collected, how well is it represented, were they able to follow the instructions and collect constructive data at good intervals?
- Check the graphs they have drawn, how accurate are they in the graphs? Does it give the correct picture of what happens when ice is heated? Can they use their graph to identify the melting point of the graph?

### **Teaching guidelines for activity 4.12**

- Let the learners use two cement blocks to support the block of ice as shown in the learner's book. Ensure that they tie the weights at the end of the wire and hang them on the block. What happens to the wire and the piece of ice? Are they able to note the effect of by pressure on the piece of ice?
- What is the effect of using lighter weights? Does it increase the pressure or lower it?

### **Assessment opportunities**

#### **Conversation**

Ask them questions as they do the activities to see if they are able to note the effects of pressure on solids. They don't have to be right, as you will clarify for them the points as you discuss with them.

#### **Product**

Give the learners some questions from reference materials on the effects of temperature on solids. Let them answer them in their books; Guide them to master the facts.

## **4.8 Effect of change in temperature on liquids**

### **Specific learning outcome**

*By the end of this section the learners should be able to explain the effects of change in temperature on liquids.*

### **Teaching guidelines for activity 4.13**

- Ask the learners to draw a table with two columns, one for time and the other column for temperature as the one given in student's book in their exercise book.
- With your guidance let some learners take the reading. What can they note about the temperature of the water at the initial stages? Are they able to note that at some point the temperature remains constant? What is the reason for this observation?

- Provide the learners with graph papers to draw the graph of temperature ( $^{\circ}\text{C}$ ) against times. What can they state about the shape of the graph? Can they be able to explain the graph?
- Guide the learners to read the boiling point of water from the graph.

### **Boiling point of methylated spirit**

#### **Teaching guidelines for activity 4.14**

- Warn them that methylated spirit is highly flammable. Thus they should ensure that all the glasses ware is securely clamped. Can they explain why it is not advisable to heat the methylated spirit directly?
- They should then add anti bumping granules into the beaker then put it in a water bath. Are they able to identify the boiling point of methylated spirit? Guide them in their discussion on determining the melting point of methylated spirit.

### **To draw the cooling curve of candle wax**

#### **Teaching guidelines for activity 4.15**

- Let the learners obtain a test tube and fill it with frozen candle wax. Ask them to lower it into a beaker containing tap water.
- Ensure they heat the water in the beaker as they record the temperature after every 30 seconds. They should record the temperature until all the candle wax melts.
- Guide them to lower the hot water and place it on the cooling table as they collect data for the cooling candle wax. Are they able to not down the temperature accurately?
- Provide graph papers for them to draw a graph of temperature ( $^{\circ}\text{C}$ ) against time (s). How well are they able to draw the graph? Are they able to note the melting point of wax?

### **Assessment opportunities**

#### ***Observation***

Observe the learners as they do the activities. Are they able to note down the correct reading from the thermometers they are using? Guide those who may be having difficulties.

#### ***Product***

After the learners have drawn the graph on a graph paper mark their work and guide those who may having difficulty in explaining and mastering the concepts. Are they able to interpret the graphs they have drawn?

## Factors affecting boiling point

### Teaching guidelines for activity 4.16 and 4.17

- Ask the learners to heat a salt solution in a test tube as they record the temperature at fixed intervals. What is the difference between the temperatures they are recording and the temperatures they recorded on heating pure water in activity 4.13? Lead them through a class discussion on their findings
- What is the boiling point of the solution? Are they able to note the effect of the addition of impurities to the boiling point?
- Ask them to do activity 4.17. Are they able to note the effect of pressure on boiling point of substances?

### Assessment opportunities

#### *Conversation*

Ask them questions as they do the activities. Are able to state and explain how different substances affect the boiling point. They don't have to be right, as you will clarify for them the points as you discuss with them.

#### *Product*

Use this opportunity to ascertain whether the specific learning outcomes have been achieved and identify challenging areas to be discussed with learners during remedial hours.

## 4.9 Evaporation

### Specific learning outcome

*By the end of this section the learners should be able to explain how evaporation occurs and its effects.*

### Teaching guidelines for activity 4.18

- Ether fumes are very dangerous thus it will be prudent to emphasize to learners to be careful as they do the activity
- Ask them to explain what they understand by the term evaporation. Can they be able to explain when and how it takes place it takes place?
- For the learners to know the effect of evaporation ask them to put few drops of water on a wooden block and put a beaker containing ether on top. What observation do they make as they blow air into either? How can they explain why they are not able to lift the beaker with ease?

## Assessment opportunity

### *Observation*

- Observe as the learners are doing the activity. Are they able to follow the instructions given? Are they able to explain how temperature, surface area, pressure, air current and nature of liquid affect evaporation?

### *Conversation*

- Allow the learners to discuss their findings among themselves. Listen to how they discuss and guide them where necessary. This is important since it will give you opportunity to monitor and promote the communication skills of your learners. Use the opportunity to point out omissions and correct any error in each report presented.
- Can they state the similarity and differences of boiling and evaporation?

## 4.10 Sublimation and deposition

### Teaching guidelines

- Group the learners into small groups and let them do research from the Internet on the meaning of sublimation and deposition.
- Observe if they are doing the correct research. Are they able to get the meaning of sublimation and deposition? How and when do they take place? Are they able to give examples of substances that undergo sublimation or deposition?

## Assessment opportunity

### *Conversation*

Talk to the learners to find out if they are doing the right thing during the research. Are they able to give a summary of the changes of state and how temperature influences these changes?

### *Product*

Let the learners copy the summarized diagram of the changes that take place due to change in temperature, can they be able to explain how each change takes place?

Let the learners do exercise 4.3 in the learners book. Mark their work and guide them accordingly.

## Answers to numerical questions

### Exerciser 4.1

4. (a) 307 K      (b) 2 K      (c) 290 K
5. (a) 41° C      (b) -261° C      (c) 0° C  
(d) -228° C
6. Converting from question 4:  
(a) 93.20 F      (b) -635.8      (c) 626.6  
Converting from question 5  
(a) 105.8      (b) -448.6      (c) 32° F  
(d) -378.4° F

### Exercise 4.2

4. (a) 17.25 cm      (b) 27.3° C

### Topic test 4

4. 310 K
5. (a) 32° F      (b) 212° F      (c) -247.4° F  
(d) -459.4° F
12. 60° C      13. 293 K      14. 20° C

# UNIT 4

## Behaviour of light at Plane Surfaces

### Topics in the unit

Topic 5: Reflection of light on plane surfaces

Topic 6: Refraction of light on plane surfaces

Learn about:		Key inquiry questions
<p>Learners should investigate individually and in groups using appropriate equipment to understand and describe reflection and refraction; how light behaves at plane surfaces and images formed.</p> <p>Learners should research and apply the laws of reflection and refraction at plane surfaces, calculate the image position, and apply the formulae related to refraction index, real and apparent depth.</p>		<p>Why does a plane mirror reverse left and right but not top and bottom?</p> <p>How can a virtual image be formed?</p> <p>Why an object at a bottom of a glass full of water does appear nearer to the surface of the water?</p>
Learning Outcomes		
Knowledge and Understanding	Skills	Attitudes
Understand the behavior of light on plane surfaces	<p>Research laws of reflection</p> <p>Predict the outcome of a test</p> <p>Carry out tests using appropriate measures</p> <p>Collect and present results appropriate in writing or drawing</p> <p>Interpret results accurately</p> <p>Report findings consistent with evidence</p> <p>Evaluate the validity of the test</p>	Show curiosity in carrying experiments



## Contribution to student competencies

- **Critical thinking:** this unit provides the learners with an opportunity to make observations of various aspects and make a scientific conclusion. For instance when the learners will be giving a scientific explanation on the different images formed by plane mirrors. Use the learners' feedback to guide them in such away that leads to the correct responses to the questions asked in the activity. Use probing questions. By doing that, you will be promoting the critical thinking in learners. Allowing learners to hold a discussion in their groups as they attempt to respond to all questions asked in the activity. This will also promote cooperation, oral skills and leadership skills among other competences in the learners.
- **Research skills:** this unit gives the learners a wide range of opportunities for the learners to conduct a research and make conclusions. Ensure that the learners master good research skills that will be helpful even in other subjects. This will help the learners in applying science to solve everyday problems, evaluating the impact of various applications of scientific discoveries on our quality of life
- **Life skills:** as the learners discuss through out the topic they will learn lots of life skills. They would be able to do their own inventions using the knowledge they acquire from the topic. A good instance is when they make a pinhole camera.

## Links to other Links to other subjects

**Biology:** A good understanding about the propagation of light will help the learners to understand how light interacts with matter especially the plants. This knowledge will help them understand the plants that have high reflection rates on their surfaces and how they can increase growth by applying light with the right intensity. This unit will also help the learners understand how the eye works

## Cross cutting issues addressed in this unit

- **Peace education:** The learners are advised not to hurt each other. They also learn to work together in groups and learn to accept each other's contribution even when they differ from their own contribution. It is most likely that most learners will come up with different observation, explanation, and description that are inaccurate. At this point, show the learners the importance of accepting different opinions given by different learners whether right or wrong. This help to promote peace and harmony among the learners.

## Attention to special needs

- This unit has so many activities that require learners to make observation of images formed and thus use the observation to make a logical conclusion. This unit also

involves the use of the eyes to study refraction of light. Learners with visual impairment may have a lot of difficulty in making this observation thus it will be prudent to use illustrations that are well drawn on charts and large enough for them to follow through. For instance when the learners are making observations of images through a pinhole camera, well-illustrated images will aid them in comprehending the concepts. You should also encourage other learners to be patient with them when they are making the observation of such images.



## Reflection of Light on Plane Surfaces

(Student's book pages 146-184)

### Background information and /or prior knowledge

Most of the learners have experienced the nature of light and its properties in their daily lives. For instance, they have observed a beam of light rays in a dark room from an opening on the rooftop of a building; they have seen a reflection of their image on a mirror and so on. Build on these and many more familiar experiences so that the learner's curiosity to learn more is boosted. Make every lesson lively and interesting by engaging learners in all practical activities. The many activities in this topic will enable them to understand different concepts in this topic with ease.

### Subtopics

No.	Subtopics
5.1	Nature of light
5.2	Rays and Beams
5.3	Rectilinear propagation of light
5.4	Formation of shadows and eclipses
5.5	Pinhole camera
5.6	Reflection of light at plane surfaces
5.7	Image formation by a plane mirror
5.8	Application of Reflection of light at plane surfaces
5.9	Project work

### Guidelines to Suggested teaching/learning activities

#### 5.1 Nature of light

#### Specific leaning outcome

*By the end of this section, the learner should be able to define light and be able to identify different sources of light.*

#### Teaching guidelines for activity 5.1

- The learners interact with the aspect of light in almost every activity that they carry out in their day-to-day activities. During the day they use sunlight, at night they

use the moonlight. They may have also interacted with other sources of light such as the stars, candlelight and many other sources. It's from this many examples that they have come across in their surrounding environment that they should explore to complete this activity.

- Are they able to give the correct examples of sources of light? Can they differentiate between the sources that produce their own light and those that depend on the light produced by others?
- Allow learners to discuss in their respective groups and come up with harmonized points and let the secretaries or any other group members from each group to give a report to the whole class on their debate.
- This activity will promote in learners among other competencies:
  - i. Cooperation and interpersonal relation as they work in groups.
  - ii. Research and problem solving skills as they carry out research from internet and answer questions.
  - iii. Communication skills in English as they articulate their points in a discussion.
  - iv. Leadership and organizational skills as they organise themselves into groups and lead others in a discussion

### **Assessment opportunities**

#### ***Conversation***

As the learners are discussing, go round the class to the different groups. Can they be able to explain the nature of light and how it travels? What are some of the sources that they have identified? Are they able to differentiate the sources?

Note the errors the learners make in their discussion and correct them. Use this chance to assess whether the objectives have been made as you conclude this section.

## **5.2 Rays and Beams**

### **Specific leaning outcome**

*By the end of this section the learners should be able to explain beams and rays of light.*

### **Teaching guidelines for activity 5.2**

- Ask the learners to make small holes at closed ends of a tin. Let them go into a dark room and shine light from inside the tin? How does the light emerge from the holes they made? Are they able to explain why the light emerges from every hole? Are the learners able to able to explain what the observation would be if there were only one hole made on the can?

- Give them an opportunity to debate their observation in class. This group work will encourage the learners to work harmoniously as they discuss. It also helps build their oral skills as well as their listening skills.
- Let them present to the class what beams of light are, the different types of beams of light and how each travels.

### **Assessment opportunities**

#### ***Conversation***

As the learners are discussing go round the class to the different groups. Are they able to explain the path followed by light? What is the source of a beam of light? How well can they explain the different types of beams of light?

### **Transparent, translucent and opaque materials**

#### **Teaching guidelines for activity 5.3**

- Note that this activity involves using the sense of sight, that is not an excuse not to involve students with **sight problems**. You may ask them to hold the materials i.e. oiled piece of paper or a cardboard as those with normal eye sight look through them. Warn learners who might make sensitive jokes about those who have the problem. Let them know that it is not their fault to be the way they are.
- Provide the learners with locally available materials to use in the activity. The materials should have a variety of opaque, translucent and transparent materials.
- Are the learners able to classify the materials depending on their ability to allow light to pass through?
- Let them discuss in their groups whether they were able to see through the materials and suggest the general name for each material.
- What are the names given to materials that they can see through? Partially see through? And those that they can not see through them at all?

### **Assessment opportunities**

#### ***Observation***

Observe as the learners are doing the discussion. Are they doing a constructive discussion? How well are they able to identify different objects? Are the learners able to note that you can turn transparent materials into opaque materials by simply applying a layer of opaque material on top of the transparent material, for instance applying paint to a transparent glass makes it opaque?

## 5.3 Rectilinear propagation of light

### Specific leaning outcome

*By the end of this section, the learner should be able to show that light travels in a straight line.*

### Teaching guidelines for activity 5.4

- Let the learners close one of their eyes and look at a big object? Are they able to see the object? Why is this possible?
- Now ensure that they make holes in a cardboard at the same distance and place and arrange them in a straight line. As they shine a light at one end and observe from the farthest card, what can they note? Are they able to use this observation to explain how light travels?
- Ask them to have a group discussion on their observation and let the secretary write the main points.
- Ask any member of each group to present their findings from the discussion to the whole class. At this point, you can allow other members of the class to contribute to each presentation by pointing out any error or omissions.
- Alternatively take an empty can and pierce a few holes (1 or 2 mm in diameter) on all sides. In a darkroom, cover a candle flame with the can. Blow smoke (use a burning straw) or smear fire chalk dust or calcium powder around the can. Are the learners able to see where the light comes from and in what direction it travels?
- Now you can also mention about the track of light in a room and the projector in a cinema theatre.

### Assessment opportunities

#### Conversation

- Summarise the discussion by emphasizing the main point i.e. the property of light rays to travel in a straight line is called rectilinear propagation of light. Use this opportunity to correct the errors made by learners in their discussion
- As you conclude, are learners able to show that light travels on a straight line?

## 5.4 Formation of shadows and eclipses

### Specific learning outcomes

*By the end of this section, the learner should be able to analyze the formation of penumbra and umbra and illustrate how they occur.*

## Shadows

### Teaching guideline for activity 5.5

- Ask the learners to think about the shadow formed when they stand outside on a sunny day. They can also think of the differed shadows formed by trees, houses and different objects outside when there is light.
- Give the learners an opportunity to discuss about these phenomena. Are they able to explain what a shadow is and how it is formed?
- Now ask them to put a candle in front of a cardboard with a narrow opening. Are they able to observe the shadow formed on the white screen? What are the characteristics of the shadow formed?
- Give the learners an opportunity to discuss their findings and present their work to the class.

### Assessment opportunities

#### Conversation

- Listen to the learners as they are discussing, are they explaining how shadows are formed using scientific words? How well are they able to present their discussion in class?
- Does their explanation exhibit mastery of the concepts they are explaining?
- Are they able to explain what happens to the shadow when they increase the size of the opening? Are they able to note that a partial shadow is formed?

#### Product

Check the drawing the learners have drawn on how the shadows are formed. Are they able to make a logical drawing? From the drawing, can they explain how these shadows are formed?

## Eclipses

### Teaching guidelines for activity 5.6

- Ask the learners if they know what is an eclipse and if they have ever experienced one. Are they able to recall what happens when there is an eclipse? Let them do a research from the Internet and other reference materials to find more details about eclipses and how they are formed. How many types of eclipses can they note? Are they able to explain how each if formed?
- Give the learners an opportunity to use locally available materials to design an experiment to illustrate the different types of eclipses.

## Assessment opportunities

### *Conversation*

- Choose the learners at random from different groups to draw illustrations of different eclipses and explain how they are formed.
- Are they able to explain how each eclipse is formed?
- Now using readily available materials e.g. a football, a tennis ball and a touch ask the learners to demonstrate how each eclipse is formed.

### *Product*

- Look at the experiments the different learners have designed, do they illustrate well the different types of eclipses?
- Conclude the discussion by leading learner's through a discussion given in the student's book and then ask them to do question 1 and 2 of exercise 5.1 in learners book. Are they able to answer the questions correctly?
- Note that the fast learners may finish first, ask them to do the remaining question as you guide the slow learners then later let all of them do all questions in exercise 5.1.

## 5.5 Pinhole camera

### Specific learning outcome

*By the end of this section, the learner should be able to describe the nature of images, explain the functioning and solve problems involving pinhole camera.*

### Teaching guideline for activity 5.7

- Ensure the learners conduct research from the Internet and reference materials on how the pinhole camera works. From their research let them find out the characteristics of the images formed and the magnification of a pinhole camera.
- Now that the learners have knowledge of how a pinhole camera works ask them to go outside the class and observe different objects through the pinhole camera. What can they observe about the images formed by the pin whole camera?
- Can they be able to think critically and explain what will happen to the image, if the hole was increased?
- Ask any member at random, from each group to present their findings of their research. This will enable you to monitor those learners with a tendency of copying other student's work. Allow students to point out omissions or errors if any.



## Assessment opportunities

### **Observation**

Observe as the learners are doing the activities. Are they able to follow the instructions given?

### **Conversation**

Are the learners able to explain why the images of the pinhole camera are real, inverted and magnified?

### **Product**

Ask them to do exercise 5.2 in learners' book. Mark their work and use it to gauge how much the learners have understood. Are they able to answer the questions correctly? What are some of the areas that they are having difficulties? You can organize for remedial class if the learners are having difficulties. You can also encourage the learners to work in groups as this encourages peer teaching.

## 5.6 Reflection of light on plane surfaces

### **Specific learning outcome**

*By the end of this section, the learner should be able to identify different types of reflections on plane surfaces and state the laws of reflection.*

### **Teacher guideline for activity 5.8**

- Provide the learners with goggles to use while staring at the shiny objects. This is to avoid the possibility of the learners damaging their eyes as they look at the reflected light.
- Let the learners use shiny objects around the school compound e. g mirrors and shiny roofs and make an observation of what happens to sunrays when they hit the objects.
- Are they able to explain the reflection that is taking place?
- Give them an opportunity to discuss among themselves and write down notes on reflection of rays by shiny objects.

## Assessment opportunities

### **Conversation**

Listen to the learners as they make their presentation, are they able to explain the reflection of light correctly? Are they using scientific terms to explain these concepts?

### ***Product***

- Check the notes the learners have made from their discussion, have they noted down the facts about reflection of light?
- Use this opportunity to correct errors made from learner's discussion and assess them through question and answer method, to test whether the objective has been achieved as you conclude.

### **Types of reflections**

#### **Teacher guideline for activity 5.9**

- Ask the learners to use a mirror and a paper respectively to observe their image. Are they able to see their image through the mirror? Can they explain why this is possible?
- Can they be able to see their images through the paper? Can they explain why they make this observation?

### **Assessment opportunities**

#### ***Conversation***

Listen to the learners they explain their observations are they using scientific terms to express themselves?

#### **Teacher guideline for activity 5.10**

- Ensure the learners put plane mirrors vertically on a cardboard and illuminate the shiny surface with a ray box. What can they note about the rays? Ask them to sketch the rays clearly showing the angle of incident, the normal reflected ray and the angle of reflection.
- Give the learners an opportunity to discuss among themselves the diagrams they have drawn before they make a presentation to the class.

### **To verify the laws of reflection**

#### **Teacher guideline for activity 5.11**

- Caution the learners to take care not to injure themselves with the pins as they do the activity.
- Ensure the learners follow the steps given correctly as they use the results they get to fill table 5.1 in their books.

- From the data they have collected are they able to note the relationship between the angle of reflection and the angle of incident?
- Give them an opportunity to do research and design a similar experiment to verify the laws of reflection using a ray box.
- Are they able to well illustrate the steps in their experiment? How well have the learners designed their experiment? Can they be able to get the same results to make a good conclusion?

### **Assessment opportunities**

#### ***Product***

- Check the table that the learners have filled, does it show the true picture of the relationship between the angle of reflection and the angle of incidence?
- Look at the experiment the learners have designed, have they used the correct language to explain their steps? Are they able to make the conclusion on the laws of reflection?

## **5.7 Image formation by a plane mirror**

### **Specific learning outcome**

*By the end of this section, the learner should be able to state the characteristics of images formed by plane mirrors.*

### **Teacher guidelines for activity 5.12**

- Ask the learners to stand in front of a plane mirror and explain the observation about the image formed in the mirror. Can they be able to note the relationship between the image distance and the object distance?
- Is the image formed inverted or upright? How can they describe the image formed?
- In turns ensure that they use different objects in front of the mirror and note down the characteristics of the image formed.

### **Assessment opportunities**

#### ***Observation***

Observe as the learners are doing the activities. Are they able to follow the instructions given to get the correct results?

### ***Conversation***

- As the learners are discussing, go round the class and guide them through the activities as you ask them probing questions. Are the characteristics they are stating correct? Do their responses show their understanding of the images formed by a plane mirror?

### **Product**

Ask learners to do question 1 of exercise 5.3. Go around and mark their work. Note that the fast learners will finish first. Let them do the rest of the questions as you guide the slow learners.

### **Number of images formed by a plane mirror at an angle**

#### **Teaching guidelines for activity 5.13, 5.14 and 5.15**

- Ensure that the learners place two mirrors vertically facing each other with an object placed between them. Ask them to count the number of images formed
- Let them sketch the images formed by the two parallel mirrors. Are they able to sketch correctly?
- Now let them place the mirror so that the two mirrors are in contact at an angle of  $90^\circ$  in between them, followed by  $60^\circ$  respectively. Each time counting the number of images formed and sketching the image formed. Are they able to count the right number of images?
- Allow them to discuss their results and you may ask them to determine the number of images with any other angle e.g.  $30^\circ$ ,  $10^\circ$  etc.
- Let them come up with a general formula determining the number of images when plane mirrors are inclined at an angle.
- Let all the secretaries or any member from each group present their findings and all students to point out omissions or errors in each presentation.

### **Assessment opportunities**

#### ***Conversation***

- As the learners are discussing, go round the class and guide them through the activities as you ask them probing questions. Are they able to follow the instructions given? Are they using the right rays to sketch the images formed in each case?
- Talk to them and guide them as they are discussing to arrive at the general formula to get the number of images formed by mirrors in contact at an angle. Are they doing constructive discussion? How well can they reason out the formula?

## 5.8 Applications of reflection at plane surfaces

### Specific learning outcome

*By the end of this section, the learner should be able to explain some of the applications of reflection on plane surfaces in real life situations.*

### Teaching guidelines for activity 5.18

- Ask the learners to do research from the Internet and reference materials on the common applications of plane mirrors.
- Let the secretary of the group write down the main points of the research. Give the learners an opportunity to present their findings to the class. Have they got the correct applications?

### Assessment opportunities

#### *Product*

- Ask the learners to attempt exercise 5.4 in their books. Check their work as they are doing the exercise, are they giving the correct answers? Are they able to express their answers in a way that shows mastery of the concepts in the section?

Give the learners an opportunity to do the projects in the learner's book using locally available materials. Are they able to do the projects objectively? How well have they completed the projects?

### Topic assessment

- Ask the learners to do the Topic test 5 given in the learners book independently,
- Mark their work and assess the extent to which the learners have understood the concepts in the topic. Guide them accordingly.
- You may organise for remedial teaching for those who may be having challenges.

### Answers to numerical questions

#### Exercise 5.2

5. (a) 0.045      6. 0.09 m      7. 0.02 m

#### Exercise 5.3

2. (a)  $30^\circ$       6.  $60^\circ$

### Exercise 5.4

3. (a)

(i) 2

(ii) 3

(iii) 5

(iv) 11

### Topic test 5

4.  $60^\circ$

5. (a) 11

(b) 1

(c) 3

(d) 7

14. 0.2m



## Refraction in plane surfaces

(Student's book pages 185-224)

### Background information and / or prior knowledge

In primary, learners learnt about light. Using question and answer methods, establish whether the learners recall concepts learnt such as, light travels in a straight line, characteristic of images formed by plane mirror among others. This is important because most of the concepts to be learned in this part of the topic require some applications of the concepts already learnt.

You may show effects of refraction through formation of a rainbow, shinning in desert, shadow and formation of other practical observation depending on the locality of the school and the experiences of your students. This will develop curiosity in learners to learn more from the topic and also make the topic interesting and lively.

Some words used in this topic may be new and complex to the learners e.g. the word phenomenon will sound complex the to the students. Give them as an assignment to use the Internet to research on such words. You may also allow time for the discussion.

### Subtopics

No.	Subtopics
6.1	Phenomena of refraction of light
6.2	Refraction of light through a prism

### Guidelines to Suggested teaching/learning activities

#### 6.1 Phenomena of refraction of light

##### Specific learning outcome

*By the end of this section, the learner should be able to explain phenomenon of refraction of light.*

##### Learning activities

##### Teaching guidelines for activities 6.1

- Ask the learners to dip a ruler or their pen into a beaker of water. Can they note that the pencil appears to bend? What causes this observation
- Can they be able to state the effect of this observation in real life?

### **Teaching guidelines for activities 6.2**

- Learners having done activity 6.1 they should have noted that the bending of the ruler is the effect of light travelling from one medium to another.
- This activity gives them an opportunity to further explain scientifically why that happens.
- Let them pass a beam of light through a glass block in a semi dark room and observe the path taken by the ray.
- What path does the ray follow? What can they conclude on the path taken by the ray?
- Give them an opportunity to design an experiment using pins to show how light rays travel.

### **Assessment opportunities**

#### ***Conversation***

As the learners are discussing go round the class to the different groups. Can they be able to state the facts on the path taken as light travels?

Can the learners use the conclusions they have made in this activity to explain scientifically the observation they made in activity 6.1?

#### ***Product***

Check the experiment the learners have designed. Do their experiment show a chronological flow? Can they use the experiment to show how light rays travel?

Give exercise 6.1 as an assignment allow the students to exchange their books and guide them on how to mark the assignment this promotes honesty and trust among the students.

### **Law of refraction of light**

#### **Teaching guidelines for activities 6.3**

- Explain to the learners how they can obtain a sine of an angle. This concept was learnt in mathematics. Can they be able to recall this concept that they learned in mathematics? It is important for the learners to recall this concept as it will greatly be used in this topic.
- Demonstrate to them how to setup the apparatus and how to get the values of  $r$  and  $i$  from the setup.
- Let them use the ray box to get  $i$  and  $r$  for different angles to complete table 6.1.
- From the data they have collected, let them calculate and complete the table. What can they notice about the ratio of  $\sin i$  and  $\sin r$ ? Can they explain the value they have obtained? How can they relate their conclusion to the laws of refraction?



### Teaching guidelines for activities 6.3

- Now, still maintaining the same groups used in activity 6.3 or you may consider reorganise them, ask learners to do activity 6.4 in the student's book. It is important learners to work in groups but appropriate one (i.e., gender sensitive and of different abilities). The groups should be as small as possible in terms of membership to reduce cases of some members not participating. This will promote leadership skills, cooperation and teamwork among the learners.
- Let the student perform activity 6.4. Show that incident ray refracted and normal at the point of incidence all lie on the same plane. You may use a white plain paper to show the planes. This experiment is popular for schools without ray boxes and electricity. However, it is difficult for students. You should first of all deal with the concept of "No parallax method.
- Can they use their observation verify Snell's law?

### Assessment opportunities

#### *Conversation*

Ask the learners in turns to state the conclusions they have made from the activities and how they relate to Snell's law. Are they able to explain? How well can the learners state Snell's law?

#### *Product*

Check the calculation the learners have done in table 6.1, How accurate are the calculations? Does the calculation help them arrive at a conclusion that the ratio between sine  $i$  and sine  $r$  are always constant for any given set of angles?

### Refractive index

#### Specific learning outcome

At the end of this section the student should be able to:

- Define refraction index*
- Determining refractive index of a material using different methods*
- Solve problem on refraction*

### Teaching guidelines for activities 6.5

- Before the learners do activity 6.5, guide them through the discussion given in the learner's book. Help them solve example 6.1 and 6.2. After that copy example 6.3 and 6.4 on the board and tell the learners to close their books. Choose learners at

random to lead the others to do these examples on the board. This ensures maximum participation by the learners thus encouraging teamwork.

- Now ask them to place a mirror perpendicular to the refracted ray of light. What happens to the refracted ray as it strikes the mirror? What path does the ray follow? What can they explain about the path the ray follows?

### **Assessment opportunities**

#### ***Observation***

Observe as the learners are placing the mirror perpendicular to the refracted ray. Are they able to achieve this?

#### ***Conversation***

- As the learners are discussing the examples, note the way they are using facts to tackle the examples. How well can they relate the information they have learned on laws of refraction to solve the examples? Are they able to give the right explanation?

#### ***Product***

- Select some questions from exercise 6.2 and ask the learners to solve them in class. Are they able to apply what they have learned to solve the questions?
- Let those who have solved the questions well lead others in solving the questions. This will help the learners to develop cooperation in the peer teaching. Give the learners the rest of the questions as an assignment. Ask them to write down every step as they are solving the questions this will help them master the laws used in the calculation.

### **Real and apparent depth**

#### **Teaching guidelines for activities 6.6**

- Let the learners put a coin or a small stone at the bottom of a container of water. Ensure that they observe the coin perpendicularly this is to avoid parallax error. What can they observe about the height of the coin? What causes the coin to appear like it is raised?
- Now let them look at the stone from an angle. What do they observe? Can they use their observation to explain real and apparent depth?

#### **Teaching guidelines for activities 6.7**

Ask the learners to take a beaker containing clean water and measure the apparent depth

and record it down. Ensure they locate the image placed at the bottom of the container using a search pin. Let them record the apparent depth of the object. Are they able to locate the object and locate the apparent depth?

Using the two values they have recorded can they be able to determine the refractive index of water?

After they have done their calculation give them the value of the refractive index of water, are their values accurate?

### **Assessment opportunities**

#### ***Observation***

Observe as they do the activities, are they able to locate the apparent depth of the objects? How are they explaining the difference between apparent and real depth?

#### ***Conversation***

Guide them through examples 6.6 and 6.7. Ask them to do example 6.8 in their books, are they able to calculate the gradient of the graph? How can they get the refractive index from the graph? Does their values resemble the value in the learners book?

#### ***Product***

Ask learners to do questions 1-3 of exercise 6.4. Go round the class mark their work. How well are they solving the questions? This is the best opportunity to identify the learners who are having difficulties and help them. You can also encourage them to discuss amongst themselves for those who have already mastered the concepts. This peer training is important as it increases self-esteem and also encourages cooperation among the learners. Give the rest of the questions as an assignment. This will help the learners do further research thus translating into better understanding.

### **Teaching guidelines for activities 6.8**

- Review reflection on plane surfaces where  $i=r$
- Provide learners with Semi circular glass block, Paper protractor. And ask them to measure the incident ray and the angle of refraction. Let them increase them keep increasing the angle of incidence until they are unable to measure the angle of refraction. What angle of incidence does this represent? How can they describe this angle? What happens for the observation they have made to be to be possible?

## Assessment opportunities

### *Conversation*

As they do the activity you may ask learners questions and allow them to answer. From the answers they are giving, are they following? Are they able to explain that critical angle is the angle of incidence beyond which rays of light passing through a denser medium to the surface of a less dense medium are no longer refracted but totally reflected? Can they explain why the ray is totally reflected?

### *Product*

Copy examples 6.9 to 6.11 on the board and ask the learners to do them in their books. Are they able to solve them without referring to the book? They may discuss with their partners to solve them this encourages cooperation among the learners. Are they able to get the same solutions as those in the books? How well have they organised their work to arrive at the answers?

## 6.2 Refraction of light through a prism

### Specific learning outcome

*At the end of this section the student should be able to*

- i. Explain refraction of light through a glass prism*
- ii. Explain dispersion of white light and combination of colours*
- iii. Give the applications of total internal reflection*

### Preparation

#### Teaching guidelines for activities 6.9

- Show to the class the two types of glass prisms. Ask them to measure the angle of the triangle making the base of the glass prisms. Are they able to show which prism is equilateral and which one is a right angle prism?
- Ask the learners to place glass prism on a white paper. Ensure that the prism is lying on its base. Let them shine an incident light on edge CA. What happens to the ray of light as it enters and leaves the prism?
- How can they compare the behaviour of the ray as it enters and as it leaves the glass prism?

### **Teaching guidelines for activities 6.10**

- In case there is no dark room in the school you can cover the windows of the classroom with dark curtains so as to carry out the activity.
- Ensure that learners from each group are focusing a narrow beam to the prism. Are they able to explain why a single beam is used?
- Let them adjust the angle of incident until a distinct band of colours is seen. How are they able to explain why it is possible to obtain a band of colours from a single white light?
- How many colours can they identify? Is the angle of deviation same for all colours?

### **Assessment opportunities**

#### ***Observation***

Observe as the learners are doing the activity, are they able to note down the observations made correctly. Encourage them to discuss among themselves for the right explanation of the observation they have made.

#### ***Conversation***

Ask the learners if they are able to explain how the band of different colors is formed from the white light. Listen to their explanations are they able to use scientific words to explain this phenomena?

#### ***Product***

Let the learners do questions 4-10 in exercise 6.4 as a supervised practice. Check the answers they have written down. Are they able to answer the questions correctly? How well have they explained their answers?

Give exercise 6.5 as a study exercise that's students do for practice in study group.

### **Teaching guidelines for activities 6.11**

- Ask the learners to place a prism on a white paper. Let them direct a ray at an angle of  $60^\circ$  followed by  $40^\circ$  each time tracing the path followed by the ray. Are they able to trace the paths accurately?
- Guide them to keep decreasing the ray until the angle of incidence is zero. How can they explain what happens to the ray as it reaches the edge of the prism? What causes the observation that they have made?

## Assessment opportunities

### *Conversation*

Select learners at random to lead the others through examples 6.12 and example 6.13 on the board. How well can they discuss the examples? Are they able to explain each step of the example? The other learners can assist through a class discussion this helps build cooperation among learners.

## Application of total internal reflection of light

### Teaching guidelines for activities 6.12

- Guide the learners to shine two rays through a glass prism. Let them filter one of the rays using a blue filter so that they can be able to differentiate the two rays.
- What happens to the two rays as they pass through the glass prism? Can they be able to explain what causes the observation they have made?

## Assessment opportunities

### *Conversation*

Give the learners an opportunity to explain what happens to the rays as they pass through the glass prism. Are they able to explain scientifically why the upper ray emerges as the lower ray? Are they able to explain where this observation is applied in real life?

### Topic Assessment

Ask learners to do questions all questions in the topic test as a CAT. Supervise them and mark their work. Guide them appropriately.

Form study groups and give the group's specific but different problem to solve and report to the rest the class.

## Answers to numerical questions

### Exercise 6.2

3. (a) 50                      (b) 35                      (c) 133  
5.  $1.875 \times 10^8 \text{m/s}$                       6. (b) 48.3

### Exercise 6.3

4.  $6.25 \times 10^{19}$  electrons                      5. 3A  
6. (a) 1.2c                      (b)  $7.5 \times 10^{18}$  electrons

### Topic test 6

- |                             |           |                                |      |
|-----------------------------|-----------|--------------------------------|------|
| 1. C                        | 2. A      | 3. B                           | 4. A |
| 5. B                        | 6. A      | 10. (b) 1.45 (b) 14.60 , 68.70 |      |
| 11. 2.40                    | 12. 21.6° | 14. 1.25                       |      |
| 15. (b) $2 \times 10^8$ m/s |           | (c) $3 \times 10^8$ m/s        |      |

**Topics in the unit**

Topic 7: Introduction to static electricity

Topic 8: Introduction to current electricity

Learn about	Key Inquiry questions
<p>Learners should investigate how like charges of electricity repel each other whereas unlike charges attract each other by charging ebonite rods. They should test out their ideas about conductors and insulators, and relate this to their own experience of static electricity.</p> <p>Learners should construct simple electric circuits using torch batteries and bulbs in series and parallel and explain the function of various circuit components such as switches and their symbolic representation. They should design fair tests to measure the effect of increasing voltage through the brightness of bulbs and using meters, and research the relationship between volts and amps, how they are measured, leading to a basic understanding about Ohms' Law. They should learn about the sources of electromotive force and the difference between primary and secondary cells, and apply their learning about conductors and insulators to current electricity.</p>	<p>Why is electricity classified into current electricity and static electricity?</p> <p>Why does an accumulator of a car have to be topped up with distilled water at frequent intervals?</p> <p>How would you protect your lead accumulator?</p> <p>How do you measure electric current?</p> <p>How can we differentiate between a dry cell and lead accumulator?</p>



Learning outcomes		
Knowledge and Understanding	Skills	Attitudes
Understand the concept of static electricity and of the flow of electricity around circuits	Researching using a range of sources Posing questions and predict what might happen Designing fair tests Use appropriate measures Collect and present results appropriately Interpret results accurately Report findings appropriately	Be willing to predict based on prior learning

### Contribution to student's competencies

- **Creative and critical thinking:** setting up electrical circuits, predicting based on present evidence, selecting appropriate apparatus and suggesting experimental procedures, drawing conclusion from evidence, using a variety of measuring devices (ammeter, voltmeter), reading scales of electrical meters, recording data and presenting them suitably, distinguishing and co-relating different physical quantities (current, voltage, resistance), conducting a fair test, applying science to solve everyday problems, wiring plugs, handling electrical appliances safely .
- **Cooperation and teamwork** is encouraged through the discussion in the activities. The learners are required to work harmoniously among themselves to attain the requirement of the activity.

### Links to other subjects

Structure of an atom in chemistry: The learners learned about the structure of atoms in chemistry, this knowledge is applied in this topic to understand how the atoms can be loose or gain an electron to become charged.

Geography (formation of clouds and lightening): They will learn in this topic how they can stay safe from lightening by using the knowledge they will learn to build lightening arresters.

### **Cross cutting issues addressed in this unit**

- Environment – learners are sensitized about danger during rains. That is; it is not safe to shelter under trees when it's raining. This is because trees are good conductors of charges and touching a tree you risk of being electrocuted during rains. Learners are also sensitized on conservation of environment. For instance they are advised not to cut trees because cutting trees leads to deforestation.
- Allow learners to hold a discussion in their groups as they attempt to respond to all questions asked in the activity. This will promote cooperation, oral skills and leadership skills among other competences in the learners
- Students with visual impairments should be paired with the other learners to help them identify components and construct simple circuit by the sense of touch. (Inclusive education)



## Introduction to static electricity

(Student's book pages 226-234)

### Background information and /or prior knowledge

The study of electrostatic is the study of the behavior of electric charges, which are not in motion (at rest).

To understand the concept of a charge, think about an atom, which is electrically neutral. Because it is composed of equal number of positive charges and negative charges in form of protons and electrons respectively (neutrons are electrically neutral). The structure of the atom is such that the protons and neutrons are tightly bound while the electrons encircling the nucleus are relatively easier to dislodge. Hence the addition or removal of electrons from a neutral atom will cause it to become either positively or negatively charged.

### Subtopics

No.	Subtopics
7.1	Types of static charges
7.2	Origin of charges
7.3	Types of charges
7.4	The law of electrostatics

### Suggested teaching/learning activities

#### 7.1 Types of static charges

#### Specific learning outcome

*By the end of this section the learners should be able to state the types of electrostatic charges*

#### Teaching guidelines for activity 7.1

- Ask them to take the comb near a stream of water. The stream of water should not be coming out of the tap with high pressure; this may cause the learners not to see the water being attracted. Ask them to state what they observe.
- If there are no taps in the school one of the group members can pour water slowly from a beaker or container as the other brings the comp near the pouring water.

- Now let them rub the comb (polythene strip) through hair or a cloth so much, and then slowly take it to the stream of water. What happens to the stream of water? Are they able to note that by rubbing the polythene strip they charged it? What happens to the balloon when they rub it and bring it close to the wall?
- Allow them to discuss their observations; can they be able to state the different types of electrostatic charges?

### **Assessment opportunities**

#### ***Observation***

Observe as the learners are discussing through the activity, are they able to assign themselves roles as they do the activity? As one is doing the practical work, another person should be writing down the observation this helps build teamwork among the learners. How well can they explain why the charged rod attracts pieces of paper?

#### ***Conversation***

As the learners are discussing go round each group and ensure that that they are doing the right thing. Are they able to discuss constructively?

(They don't have to be right at this moment but ensure they are doing they are discussing constructively.)

- Summarise the activity by helping the learners know that the comb was able to attract the stream of water because it was charged. But before, it was not able to do so because it was not charged. When a body is not charged, it does not attract other objects when it is brought near another object but when an object is charged, it attracts other objects.

## **7.2 The law of electrostatics**

### **Specific learning outcome**

*By the end of this section the learners should be able to state the law of electrostatics*

### **Teaching guidelines for activity 7.2**

- Ensure the learners rub an ebonite rod with silk and suspend the rod with a stirrup (support) and thread. Ask them to bring a charged polythene rod near one end of the ebonite rod. What is their observation? Can they state the type of charge the polythene rod acquires?
- When they bring the second charged rod near the first one, can they note that the two rods rebel each other thus move away from each other?

- What observation do they note when they use a Perspex rod in place of glass rod? Are they able to note that a Perspex rod acquires an opposite charge from that acquired by a polythene rod? Are they able to explain why this is so?

### **Teaching guidelines for activity 7.3**

- Unsure the learner's charge the Perspex rod and a glass rod. Guide them to suspend the different rods and bring different rods as instructed in the learner's book as they note the different observations.
- They should use the observations they make to complete table 7.1 in their books. From the observations they have made what can they conclude about the opposite and negative charges?
- Can they be able to use their conclusion to state the law of electrostatics?

### **Assessment opportunities**

#### ***Observation***

Observe as the learners keep using different rods to do the activities, are they able to appreciate that by rubbing different rods on different materials they acquire different charges?

#### ***Conversation***

- Listen to the learners as they present their findings, are they able to note the charges acquired by different rods when rubbed on different materials? How well can they explain why the rods attract or rebel each other?

#### ***Product***

Check the table that the learners have filled, have they made the correct entries? What can they conclude from the table they have filled? Ask the learners to state the law of electrostatics.

## **7.4 Conductors and insulators**

### **Specific learning outcome**

*By the end of this section the learners should be able to differentiate between conductors and insulators*

### **Teaching guidelines for activity 7.4**

- Provide the learners with a variety of locally available materials that are conductors and insulators.

- Let the learners suspend a positively charged glass rod and let them use it to investigate what materials are conductors and which ones are insulator. Are the learners able to identify insulators and conductors? What is the difference between the two?
- From the materials they have sorted how many categories of insulators and conductors have they got?

### **Assessment opportunities**

#### ***Conversation***

- Go round the groups as the learners are sorting the materials. Are they able to sort the conductors from insulators? Can they be able to explain how they are able to do that?

## **7.4 Effects and applications of electrostatics**

### **Specific learning outcome**

*By the end of this section the learners should be able to state the effects and applications of electrostatics.*

### **Teaching guidelines for activity 7.5**

- Ask the learners to sprinkle some chalk dust on a mirror and observe what happens.
- Are they able to note the difference when they rub the mirror with a cloth?
- What are the applications that the learners have state? Are they able to explain these applications?

### **Assessment opportunities**

#### ***Observation***

Observe as the learners are discussing the activity. State facts?

#### ***Conversation***

- Look at the notes that the learners have made on the applications electrostatics, are they able to state the correct applications and explain them?

### **Answers**

For non-numerical questions, the learners can get most of the answers from the discussions given in student's book or from the internet and any other reference books. Mark the student's work and use it to guide them appropriately.



## Introduction to current electricity

(Student's book pages 235-267)

### Background information and / or prior knowledge

Introduction to Current electricity deals with the basic ideas about electricity. The main point in this topic is how to operate a simple electric circuit. Since the learners have studied a simple electric circuit in primary, allow them to do most of the activities in groups and report their findings to the rest of the class.

Learners were introduced to the concept of simple electric circuit in primary. Review what they covered in Primary, explaining the importance and production of electricity, identifying sources of electricity and explaining danger of electric current. Assigning groups different concepts covered in primary in advance can do this. You can also allow the groups secretaries to make presentation in class. Inform the learner the career opportunities e.g. electrical engineers, technologist, technicians etc.

### Subtopics

No.	Subtopics
8.1	Simple electric circuit and its components
8.2	Arrangement of bulbs and cells in an electric circuit.
8.3	Electric current
8.4	Potential difference
8.5	Ohm's law
8.6	Chemical cells

### Suggested teaching/learning activities

#### 8.1 Simple electric circuit and its components

#### Specific learning outcome

*By the end of this section, the learner should be able to define simple electric circuit and its components.*

#### Teaching guidelines for activity 8.1

- Since cells and batteries are consumable buy them a day before the start of this topic. In case of rechargeable batteries have them charged properly before the topic starts.

- Make sure you alert the students to disconnect their circuit once they are through with making the observation. This will promote standardization culture of saving energy. Remind them of the correct way to dispose used up cells, this will help learners appreciate proper waste management thus helping in reducing environmental pollution.
- Let the learners make the connection of a circuit as shown in the learner's book. Are they able to do the right connection especially at the terminals of the cell?
- What can they note as they close the circuit? Does the bulb light? What makes the bulb to light? What happens when they interchange the connection on the terminals of the battery?

### **Assessment opportunities**

#### ***Observation***

Connecting the circuit may be difficult for the learners at the beginning. You may have to demonstrate to the class how to set one. Then move to each group to check the circuit before switching on. Are they able to make the connection?

#### ***Conversation***

The main source of errors maybe in the lose connection at the cell terminals and at the components .Can they be able to follow how to connect the simple circuit? How well have they explained what happens to the bulb when they open and close the circuit respectively?

## **8.2 Arrangement of bulbs and cells in an electric circuit**

### **Specific learning outcome**

*By the end of this section the learners should be able to arrange the cells and bulbs. They should also be able explain the effect of arranging the bulbs or cells in series or parallel.*

### **Bulbs in series**

#### **Teaching guidelines for activity 8.2**

- Let the learners use the bulbs and the dry cell provided to connect the bulbs in series. Are they able to make a good connection of the bulbs in series? Is there a difference in brightness between when one bulb is connected and when the two bulbs are connected?
- Allow them to discuss their observation from the activity. This will enable learners to realize the importance of teamwork and it will enhance communication skills in them.



## **Bulbs in parallel**

### **Teaching guidelines for activity 8.3**

- Ask the learners to connect one bulb in a circuit and note its brightness. They should also connect the two bulbs in parallel and note their brightness
- How does the brightness of the bulbs compare? Will addition of bulbs in the circuit change the brightness of each? Can the learners explain the reason for their answer?
- Give the learners an opportunity to discuss their observation from the activity. This will enable learners to realize the importance of teamwork and it will enhance communication skills in them.
- Can they be able to give an instance where this kind of connection is needed?

## **Cells in series**

### **Teaching guidelines 8.4**

- The learners have already covered how to connect the bulbs in series. In this activity allow them connect the cells in series and let them note the brightness of the bulb
- How can they compare the brightness of a bulb when one cell is used and when two cells are connected in series?
- Can the brightness of the bulb change if more cells were added in the circuit?
- Give the learners an opportunity to discuss the observations among themselves. Are they able to discuss contractively?

### **Teaching guidelines for activity 8.5**

- This is an investigation activity. Ask the learners to modify the connection in activity 8.4. In this activity they should connect the cells in parallel.
- Check the procedure they have written and the drawing of the circuit they are going to draw, does it have a chronological flow? Is the circuit well presented?
- Ask them to compare the brightness when two bulbs are connected and when they connect one bulb. Does the brightness change? Are they able to explain their observation.
- Allow them to discuss their observation from the activity. This will enable learners to realize the importance of teamwork and it will enhance communication skills in them.

## Assessment opportunities

### *Observation*

- Ask the learners to report their findings through their secretaries. Time may be insufficient, so let each group give a brief summary. Observe the learners as they connect the cells. Are they making the right connection? Can they be able to explain the different connections they have made? As they do the connections, do they seem to know what they are doing?

### *Product*

Select some questions from exercise 8.1 and let the learners do them as you mark their work. Are they able to solve the questions? How well can they do the presentation to the class? You can choose the learners at random to do different questions on the board as the other learners are helping in solving the questions by answering the questions at random. Give the learners the remaining questions to do as an assignment

## 8.3 Electric current

### **Specific learning outcome**

*By the end of this section the learners should be able to explain what electric current is, how it is measured and how it is calculated.*

### **Teaching guidelines 8.6**

- In Primary the students were introduced to electricity. Can they be able to recall what they were thought? At this point let the learners differentiate between electricity and electric current. Are they able to state the difference? Emphasize to the learners that the cells/batteries are not the source of electrons.
- Let them pour some water into a rectangular straw. Ask them to raise one side of the straw and observe what happens to the water in the straw. Can they explain why the water pours out of the straw from one side?
- Now let them use this analogy to explain how electrons flow in a circuit. Are they able to explain? How well can they be able to explain this concept?
- Let them discuss how electric current is calculated. They can do some research from reference materials to help them explain how electric current is calculated.

## Assessment opportunities

### Conversation

- With the student's book closed. Give examples 8.1 – 8.3 as practice exercise. Are they able to solve the examples? Let them discuss the examples in a class discussion. Are they able to do the questions?

## Measurement of electric current

### Teaching guidelines for activity 8.7

- Provide the learners with the materials required for activity 8.7 in the learner's book. Ask them to select an ammeter from the instruments. Are they able to identify the ammeter?
- Let them note down the scale of the ammeters. Can they be able to take a reading from the scale? How are the different scales on the ammeter taken?
- Guide them to do the connection of the ammeter in the circuit. Ensure that they are doing the connection to the right terminals, as it is a common problem among learners during the connection.
- Is there any effect in shifting the position of the ammeter in the connection? Can they be able to give a reason why an ammeter is always connected in series in a circuit?
- Insist on the drawing of the instrument scale to understand the various scale ranges i.e. 0-1.0 mA, 0-1A, 0-1.0uA etc. Then show which terminals to use for a given range. This activity should be followed by activity on how to use an ammeter to measure current in series. Explain and even demonstrate, what series connection mean i.e. +ve to +ve and -ve to -ve or left to right and right to right (let the students hold their hands).

### Teaching guidelines for activity 8.8

- Provide the learners with an analog ammeter. Let them identify the scale they will use to take a reading. What difference do they note between the two scales? Can they be able to take a reading using either of the reading?
- Let them sketch the range of the scale they have used to take the reading. Can they be able to tell what one division represents in the scale?
- Give them an opportunity to discuss with their partners how the magnitude of the current can be read from the ammeter.

## Assessment opportunities

### *Observation*

Observe the learners as they do the activities. Are they able to read the ammeter? Are they making the right sketch of the scale of the ammeter in their books?

### *Conversation*

- Let the learners discuss example 8.4 and solve the example as a group. How well can they handle the example? Are they having any difficulty in handling the example given?

### *Product*

Select some questions from exercise 8.1 and let the learners discuss them and solve them, are they able to solve them? Do their answers depict well understanding of the concepts they have learned? As the learners discuss it enhances peer teaching that helps the learners to understand the concepts better. Their oral skills are also developed as they express their opinions in the group. Give the rest of the questions as an assignment for the learners to work them out. This enhances self-evaluation to see where the learners have no understood.

## 8.4 Potential difference

### Teaching guidelines for activity 8.9

- Let the learners to conduct a research and in their research find out:
  - i. What is potential difference
  - ii. What is the SI unit of potential difference
  - iii. What is the definition of a volt
- Give them an opportunity to compare their findings with the rest of the class. Have they carried on the correct research? Are they able to present their findings to the class? Can they explain the relationship between the work done and the volt?

## Assessment opportunities

### *Conversation*

Listen to the learners as they discuss the points they got from their research, Are they able to use scientific terms to explain their points?

## Measurement of Voltage

### Teaching guidelines 8.10

- Provide the learners with digital and analog voltmeters. Let them study the scale on the analog voltmeters. Can they be able to take the reading? How does a digital voltmeter work? Can the learners be able to explain how the voltmeter is connected in a circuit?
- Give the learners an opportunity to design an experiment to show how the voltmeter is used in a circuit.
- Check the experiment the learners have designed, are they able to show in their experiment how a voltmeter is used in a circuit?

### Assessment opportunities

#### *Observation*

Observe as the learners are doing the activity, are they able to take the reading from the voltmeter? Are they able to differentiate between the two scales of the analog voltmeter?

#### *Product*

- Look at the experiment the learners have designed to show how a voltmeter is used in a circuit; is their experiment well illustrated? How well have they organized their work?
- Learners to do exercise 8.2 questions 3,4 and 7 in class. Select some learners at random to lead the others in doing the questions on the board. Are they able to solve the questions with ease?
- Guide them as they discuss to ensure that each learner has understood the steps of each question. Give the learners the rest of the questions as an assignment. They should do more research from the Internet as they answer the questions so that they can develop more question answering techniques in measurement of potential difference related questions.

## 8.6 Chemical cells

### Specific learning outcome

*By the end of this section the learners should be able to explain the different types of chemical cells and their uses*

### **Teaching guidelines for activity 8.11**

- Ensure the learners push the copper slits into the lemon. Ask them to ensure that the plates don't touch each other.
- Can they note any deflection on the galvanometer? Can they be able to explain what cause this deflection?

### **Assessment opportunities**

#### ***Observation***

Observe the learners as they do the activities. Are they able to make the right connections?

#### ***Conversation***

Through question and answer method assess whether the objectives have been achieved.

- Randomly pick any group member to present their findings to the whole class.

### **Teaching guidelines for activity 8.11**

- Ensure that the learners complete this activity without referring to the discussion in the learner's book.
- Let them connect the bulb with two copper electrodes and dip them in the electrolyte. Does the bulb light? What makes the bulb to light? What happens to the brightness of the bulb after some time?
- Give them an opportunity to discuss their observation in groups and write down their conclusion. Are they able to do a constructive discussion?

### **Assessment opportunities**

#### ***Observation***

Observe the learners as they are dipping the copper electrodes in the electrolyte; ensure that the electrodes do not touch. Are they able to make the correct observation? Does the bulb become dim with time? How are they explaining this observation?

### **Teaching guidelines for activity 8.13**

- Ask the learners to ensure that the two lead plates are clean before they start the activity. Are they able to explain why the two plates must be clean?
- Ask them to deep the lead electrodes into the dilute sulphuric acid as they observe what happens at the base of the plates. Are they able to note the deposition that happens on the plate that is connected to the negative terminal? Is the plate on the positive terminal affected? Are they able to explain what causes this observation?

## Assessment opportunities

### *Observation*

Observe the learners as they are dipping the lead in the electrolyte. Are they able to do the connection such that the two electrodes do not touch? Are they able to make the correct observation? Are they able to explain why there is a deposition on the plate connected to the negative terminal while the other remains the same?

### *Conversation*

Listen to the learners as they give the reasons for their observation, are they able to use scientific logic to explain their observation? What reasons are they giving why it is not advisable to use concentrated sulphuric acid?

## Teaching guidelines for activity 8.14

- Let the learners use lemons, wires and a galvanometer to complete the circuit as shown in the learners book. Are they able to make the right connection?
- Ensure that they connect the lemons in series as they do the activity. What can they note on the galvanometer? Let them note the deflection when one lemon is used and when two lemons are used. Is the deflection the same?

## Assessment opportunities

### *Conversation*

Listen the learners as they the learners explain what causes the difference in the deflection of the galvanometer, are they giving the right explanation? How are they relating this activity to what happens in the battery?

### *Product*

Let the learners discuss and give other examples of secondary cells. Are they able to explain how secondary cells work? How well can they explain the advantages and disadvantages of secondary cells?

Ask the learners to do exercise 8.3 given in the learner's book. Mark their work and hold a class discussion to help them understand the questions tested.

Guide the learners to do the project work given in the learners book. They can also design other relevant projects using the knowledge they have learned in this unit.

## Answers to numerical questions

### Exercise 8.1

2. 4500 C      3. 2.67 A      4.  $6.25 \times 10^{18}$       5. 3 A  
6. (a) 1.2 C  
(b)  $1.25 \times 10^{19}$  electrons

### Exercise 8.2

4. 2.5 V  
7. (a) (i) 60mv    (ii) 172.5mv      (iii) 1.725v  
(iv) 0.0684v    (v) 6.9v      (vi) 17.1v

### Exercise 8.3

2. 8 W      3. 6 V      4. 6 V

### Exercise 8.5

1. (a) 135000 J (b) 4959000 (c) 9000 V  
3. (a) 0.25 A, 960  
(b) 8.33 A, 28.8  
4. (b) 10800 KJ  
6. 21600 kJ  
7. 960 W  
8. 0.625 A

### Exercise 8.6

1. 2.4 kW

### Topic Test 8

2. 0.33A  
3. 108C  
6. 64.8c  
7. 2A  
9. 0.65 A, 53.5 A  
13. 10 A  
17. 58 000 J